



2017 Game & Season Manual



www.firstinspires.org

200 BEDFORD STREET ■ MANCHESTER, NH 03101



FOR INSPIRATION & RECOGNITION OF SCIENCE & TECHNOLOGY

FIRST[®], the *FIRST*[®] logo, *FIRST*[®] Robotics Competition, *Coopertition*[®], *FIRST STEAMWORKS*SM, *Gracious Professionalism*[®], and Sport for the Mind[™] are trademarks of For Inspiration and Recognition of Science and Technology (*FIRST*[®]). © 2016-2017 *FIRST*. All rights reserved.

Official *FIRST*[®] Robotics Competition teams and Partners are permitted to make reproductions of this manual for team and Partner use only. Any use, reproduction, or duplication of this manual for purposes other than directly by the team or Partner as part of *FIRST*[®] Robotics Competition participation is strictly prohibited without specific written permission from *FIRST*.

www.firstinspires.org

200 BEDFORD STREET ■ MANCHESTER, NH 03101



FOR INSPIRATION & RECOGNITION OF SCIENCE & TECHNOLOGY



Contents

1	Introduction.....	7
1.1	About <i>FIRST</i> [®]	7
1.2	<i>FIRST</i> [®] Robotics Competition	7
1.3	<i>Gracious Professionalism</i> [®] , a <i>FIRST</i> [®] Credo.....	7
1.4	<i>Coopertition</i> [®]	8
1.5	This Document and its Conventions	9
1.6	Translations & Other Versions	10
1.7	Team Updates	10
1.8	Question and Answer System	11
2	<i>FIRST</i>[®] STEAMWORKSSM Overview	13
3	ARENA	15
3.1	Zones and Markings	16
3.2	FIELD.....	18
3.3	GUARDRAIL.....	18
3.4	AIRSHIP	19
3.4.1	ROTORS.....	20
3.4.2	GEAR Sets.....	22
3.5	LIFTS	24
3.6	STEAM TANK.....	25
3.7	DAVIT.....	26
3.8	ROPE.....	26
3.9	TOUCHPAD.....	26
3.10	HOPPERS	28
3.11	ALLIANCE WALL.....	30
3.11.1	PLAYER STATION	30
3.11.2	Overflow LOADING STATION.....	32
3.11.3	Return LOADING STATIONS	33
3.11.4	BOILER.....	34
3.11.5	RETURN & OVERFLOW BINS.....	35
3.11.6	STEAM PIPE	35
3.12	GAME PIECES.....	36
3.12.1	FUEL.....	36
3.12.2	GEARS	36





3.13	Vision Targets	37
3.14	The Field Management System	37
4	MATCH Play	39
4.1	Periods.....	39
4.2	MATCH Setup.....	39
4.3	Scoring	41
4.4	Rule Violations	43
4.5	DRIVE TEAM	43
4.6	Logistics	44
5	Safety Rules.....	45
6	Conduct Rules	47
7	Game Rules	51
7.1	Before the MATCH	51
7.2	ROBOT Restrictions	52
7.3	ROBOT to ROBOT Interaction	53
7.4	FIELD Interaction	55
7.5	GAME PIECE Interaction	56
7.6	AUTO Period Rules	58
7.7	Human Action Rules	58
8	ROBOT Rules.....	61
8.1	Overview	61
8.2	General ROBOT Design.....	63
8.3	ROBOT Safety & Damage Prevention	64
8.4	Budget Constraints & Fabrication Schedule	66
8.5	BUMPER Rules.....	72
8.6	Motors & Actuators	79
8.7	Power Distribution.....	82
8.8	Control, Command & Signals System.....	88
8.9	Pneumatic System.....	92
8.10	OPERATOR CONSOLE.....	97
9	Inspection & Eligibility Rules.....	99
10	Tournaments.....	105
10.1	MATCH Schedules	105





10.2	Practice MATCHES	105
10.2.1	Filler Line.....	105
10.3	Measurement	106
10.4	Qualification MATCHES	106
10.4.1	Schedule	106
10.4.2	MATCH Assignment	106
10.4.3	Qualification Ranking	107
10.5	Playoff MATCHES	107
10.5.1	ALLIANCE Selection Process	108
10.5.2	BACKUP TEAMS.....	109
10.5.3	Playoff MATCH Bracket	109
10.6	REFEREE Interaction	111
10.7	YELLOW and RED CARDS	112
10.8	MATCH Replays	113
10.9	TIMEOUTS and BACKUP TEAMS	113
10.10	Pit Crews	115
10.11	FIRST® Championship Additions and Exceptions	115
10.11.1	Four ROBOT ALLIANCES	116
10.11.2	FIRST Championship Pit Crews	116
10.11.3	FIRST Championship Playoffs.....	117
10.11.4	FIRST Championship TIMEOUTS	118
10.12	Advancement Between Tournaments	118
10.12.1	Regional Events.....	119
10.12.2	Wild Cards	119
10.12.3	District Events	120
11	Glossary	125





I Introduction

I.1 About *FIRST*[®]

FIRST[®] (For Inspiration and Recognition of Science and Technology) was founded by inventor Dean Kamen to inspire young people's interest in science and technology. Based in Manchester, New Hampshire, *FIRST* is a 501(c)(3) not-for-profit public charity.

FIRST provides four programs:

- *FIRST*[®] Robotics Competition for grades 9-12, ages 14-18
- *FIRST*[®] Tech Challenge for grades 7-12, ages 12-18
- *FIRST*[®] LEGO[®] League for grades 4-8, ages 9-14 (ages 9-16 outside of North America)
- *FIRST*[®] LEGO[®] League Jr. for grades K-4, ages 6-10

Please visit our website: www.firstinspires.org for more information about *FIRST* programs.

I.2 *FIRST*[®] Robotics Competition

FIRST Robotics Competition pairs high school students with adult mentors (primarily engineers and teachers) to design and build ROBOTS that compete against one another in a high energy environment.

This varsity *Sport for the Mind*[™] combines the excitement of sport with the rigors of science and technology. Under strict rules, limited resources and time limits, teams of students are challenged to raise funds, design a team “brand”, hone teamwork skills, and build and program ROBOTS to perform prescribed tasks against a field of competitors. It's as close to “real-world” engineering as a student can get.

Each January at the Kickoff, a new, challenging game is introduced. These exciting competitions combine the practical application of science and technology with the fun, intense energy and excitement of a championship-style sporting event. Teams are encouraged to display *Gracious Professionalism*[®] and to help other teams and cooperate while competing. This is known as *Coopertition*[®].

In 2017, *FIRST* Robotics Competition will reach 85,000 high-school students representing approximately 3,400 teams. Teams come from nearly every state in the United States, as well as many other countries.

FIRST Robotics Competition teams will participate in 55 Regional Competitions, 80 District Competitions, and 10 District Championships. In addition, approximately 800 teams will qualify to go to one of the two *FIRST* Championships at the end of April, 2017.

This year's game was presented at the 2017 *FIRST* Robotics Competition Kickoff on Saturday, January 7, 2017.

At the Kickoff, all teams:

- saw the 2017 game, *FIRST*[®] STEAMWORKSSM, for the first time
- learned about the 2017 game rules and regulations
- received a Kickoff Kit that provides a starting point for robot build

I.3 *Gracious Professionalism*[®], a *FIRST*[®] Credo

Gracious Professionalism[®] is part of the ethos of *FIRST*. It's a way of doing things that encourages high quality work, emphasizes the value of others, and respects individuals and the community.





Gracious Professionalism is not clearly defined for a reason. It can and should mean different things to everyone.

Some possible meanings of *Gracious Professionalism* include:

- Gracious attitudes and behaviors are win-win
- Gracious folks respect others and let that respect show in their actions
- Professionals possess special knowledge and are trusted by society to use that knowledge responsibly
- Gracious Professionals make a valued contribution in a manner pleasing to others and to themselves

In the context of *FIRST*, this means that all teams and participants should:

- Learn to be strong competitors, but also treat one another with respect and kindness in the process
- Avoid leaving anyone feeling as if they are excluded or unappreciated

Knowledge, pride and empathy should be comfortably and genuinely blended.

In the end, *Gracious Professionalism* is part of pursuing a meaningful life. When professionals use knowledge in a gracious manner and individuals act with integrity and sensitivity, everyone wins and society benefits.

“The FIRST spirit encourages doing high-quality, well-informed work in a manner that leaves everyone feeling valued. Gracious Professionalism seems to be a good descriptor for part of the ethos of FIRST. It is part of what makes FIRST different and wonderful.”

- Dr. Woodie Flowers, National Advisor for FIRST



It is a good idea to spend time going over this concept with your team and reinforcing it regularly. We recommend providing your team with real-life examples of *Gracious Professionalism* in practice, such as when a team loans valuable materials or expertise to another team that they will later face as an opponent in competition. Routinely highlight opportunities to display *Gracious Professionalism* at events, and encourage team members to suggest ways in which they can demonstrate this quality themselves and through outreach activities.

1.4 *Coopertition*[®]

At *FIRST*, *Coopertition*[®] is displaying unqualified kindness and respect in the face of fierce competition. *Coopertition* is founded on the concept and philosophy that teams can and should help and cooperate with one another even as they compete. *Coopertition* involves learning from teammates and mentors. *Coopertition* means competing always, but assisting and enabling others when you can.

A Message from Woodie Flowers Award Recipients

The Woodie Flowers Award is the most prestigious mentoring award in *FIRST*. The award recipients as of the 2015 *FIRST* Championship created an important message for all *FIRST* Robotics Competition teams to consider as we tackle each season.

“Performing at your best is important. Winning is important. This is a competition.

However, winning the right way and being proud of what you have accomplished and how you have accomplished it is more important. *FIRST* could create rules and penalties to cover almost any scenario





or situation, but we prefer an understandable game with simpler rules that allow us to think and be creative in our designs.

We want to know that our partners and opponents are playing at their best in every match. We want to know they are playing with integrity and not using strategies based on questionable behaviors.

As you create your robots and award presentations, prepare for competition and match play, create and implement game strategies, and live your daily lives, remember what Woodie has said time and time again, and let's 'Make your Grandmother proud.'"

Woodie Flowers
Liz Calef (88)
Mike Bastoni (23)
Ken Patton (51, 65)
Kyle Hughes (27)
Bill Beatty (71)
Dave Verbrugge (67)
Andy Baker (3940, 45)

Dave Kelso (131)
Paul Copioli (3310, 217)
Rob Mainieri (2735, 812, 64)
Dan Green (111)
Mark Breadner (188)
John Novak (16)
Chris Fultz (234)
John Larock (365)

Earl Scime (2614)
Fredri Lajvardi (842)
Lane Matheson (932)
Mark Lawrence (1816)
Eric Stokely (258, 360, & 2557)

1.5 This Document and its Conventions

The **2017 Game and Season Manual** is a resource for all *FIRST* Robotics Competition teams for information specific to the 2017 season and the *FIRST*[®] STEAMWORKSSM game. Its audience will find the following detail:

- A general overview of the *FIRST* STEAMWORKS game
- Detail about the *FIRST* STEAMWORKS playing field
- Description of how to play the *FIRST* STEAMWORKS game
- All season rules (e.g. safety, conduct, game play, inspection, etc.)
- Description of how teams advance at 2017 tournaments and throughout the season

The intent of this manual is that the text means exactly, and only, what it says. Please avoid interpreting the text based on assumptions about intent, implementation of past rules, or how a situation might be in "real life." There are no hidden requirements or restrictions. If you've read everything, you know everything.

Specific methods are used throughout this section to highlight warnings, cautions, key words and phrases. These conventions are used to alert the reader to important information and are intended help teams in constructing a ROBOT that complies with the rules in a safe manner.

Links to other section headings in this manual and external articles appear in [green underlined text](#).

Key words that have a particular meaning within the context of the *FIRST* Robotics Competition and *FIRST* STEAMWORKS are defined in [Section 11 Glossary](#), and indicated in ALL CAPS throughout this document.

The rule numbering scheme uses an indication of the section in which the rule is stated plus a serial numbering system (e.g. safety rules begin with "S," game rules begin with "G," etc.). References to specific rules use this scheme (e.g. "S01" is the first rule in [Section 5 Safety Rules](#)).





Warnings, cautions and notes appear in blue boxes. Pay close attention to their contents as they're intended to provide insight into the reasoning behind a rule, helpful information on understanding or interpreting a rule, and/or possible "best practices" for use when implementing systems affected by a rule.

While blue boxes are part of the manual, they do not carry the weight of the actual rule (if there is an inadvertent conflict between a rule and its blue box, the rule supersedes the language in the blue box).

With the exception of nominal dimensions, imperial dimensions are followed by comparable metric dimensions in parentheses to provide metric users with the approximate size, weight, etc. Metric conversions for non-rules (e.g. FIELD dimensions) round to the nearest whole unit e.g. "17 in. (~43 cm)" and "6 ft. 4 in. (~193 cm)." Metric conversions in rules round such that the metric dimension is compliant with the rule (i.e. maximums round down, minimums round up). The metric conversions are offered for convenient reference only and do not overrule or take the place of the imperial dimensions presented in this manual and the field drawings (i.e. FIELD dimensions and rules will always defer to measurements using imperial units).

Some sections and rules include colloquial language, also called headlines, in an effort to convey the intent of the rule or rule set. This language is differentiated **using bold brown text**. Any disagreement between the specific language used in the rules and the colloquial language is an error, and the specific rule language is the ultimate authority. If you discover a disparity, please [let us know](#) and we will correct it.

Team resources that aren't generally season specific (e.g. what to expect at an event, communication resources, team organization recommendations, ROBOT transportation procedures, and award descriptions) can be found on the [FIRST Robotics Competition website](#).

1.6 Translations & Other Versions

The *FIRST*[®] STEAMWORKSSM manual is originally and officially written in English, but is occasionally translated into other languages for the benefit of *FIRST* Robotics Competition Teams whose native language may not be English.

A text-based version can be provided only for use with assistive devices for visually and hearing impaired persons, and not for redistribution. For more information, please contact frcteamadvocate@firstinspires.org.

In the event that a rule or description is modified in an alternate version of this manual, the English pdf version as published on the *FIRST* website is the commanding version.

1.7 Team Updates

Team updates are used to notify the *FIRST* Robotics Competition community of revisions to the official season documentation (e.g. the manual, drawings, etc.) or important season news. Between Kickoff and Stop Build Day, Team Updates are posted each Tuesday and Friday. Between Stop Build Day and the week before *FIRST* Championship Houston, Team Updates are posted each Tuesday. Team updates are posted on the [FIRST STEAMWORKS Game and Season Materials website](#) and generally posted before 5 pm, Eastern Time.

Generally, Team Updates follow the following convention:

- Additions are highlighted in yellow. **This is an example.**





- Deletions are indicated with a strikethrough. ~~This is an example.~~
- Notes that are added for clarity or explanation for the change but are not retained as part of the manual appear in bold. **This is an example.**

1.8 Question and Answer System

Questions about any **2017 Game and Season Manual** content may be asked to *FIRST* using the official [Question and Answer System](#) (i.e. “the Q&A”), which opens on January 11, 2017, noon Eastern. Details on the Q&A can be found on the [FIRST STEAMWORKS Game and Season Materials website](#). The Q&A is intended to help clarify rules, and sometimes the responses result in revisions to the text in the official document (which is communicated using [Team Updates](#)).

The Q&A is not a resource for rulings on hypothetical strategies or situations or a design review of a ROBOT system for legality. The responses in the Q&A do not supersede the text in the manual, although every effort will be made to eliminate inconsistencies between the two. While responses provided in the Q&A may be used to aid discussion at each event, per [Section 10.6 REFEREE Interaction](#) and [Section 9 Inspection & Eligibility Rules](#), REFEREES and Inspectors are the ultimate authority on rules. If you have concerns about enforcement trends by volunteer authorities, please notify *FIRST* at firstroboticscompetition@firstinspires.org.

Technical questions, e.g. an inquiry about how to check the image version on the roboRIO should be posted to the [FIRST Robotics Competition section of the FIRST Forums](#) (any technical questions submitted to the Q&A will be redirected there).





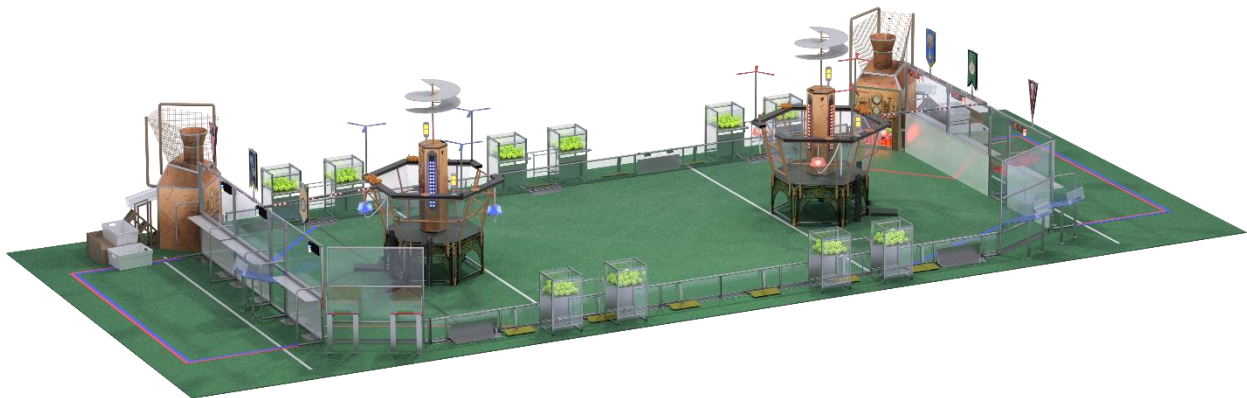
2 FIRST® STEAMWORKSSM Overview

FIRST® STEAMWORKSSM, the 2017 FIRST® Robotics Competition game, invites two adventurers' clubs, in an era where steam power reigns, to prepare their airships for a long distance race.

Each three-team alliance prepares in three ways:

1. **Build steam pressure.** Robots collect fuel (balls) and score it in their boiler via high and low efficiency goals. Boilers turn fuel into steam pressure which is stored in the steam tank on their airship – but it takes more fuel in the low efficiency goal to build steam than the high efficiency goal.
2. **Start rotors.** Robots deliver gears to pilots on their airship for installation. Once the gear train is complete, they turn the crank to start the rotor.
3. **Prepare for flight.** Robots must latch on to their airship before launch (the end of the match) by ascending their ropes to signal that they're ready for takeoff.

Figure 2-1: FIRST STEAMWORKS playing area



Each match begins with a 15-second autonomous period in which robots operate only on pre-programmed instructions. During this period, robots work to support the three efforts listed above and also get points for crossing their baseline.

Table 2-1: Auto Point Values

Action	Value
Cross the baseline	5 match points
1 fuel in high efficiency goal	1 match point, 1 kPa
3 fuel in low efficiency goal	1 match point, 1 kPa
Rotor turning	60 match points

During the remaining 2 minutes and 15 seconds of the match, the teleoperated period, student drivers control robots. Teams on an alliance work together to build as much pressure and start as many rotors as possible – but they have to be sure they leave enough time to latch on to their airship before the end of the match. Points for these efforts are awarded as shown in Table 2-2.





Table 2-2: Teleop Point Values

Action	Value
3 fuel in high efficiency goal	1 match point, 1 kPa
9 fuel in low efficiency goal	1 match point, 1 kPa
Rotor turning	40 match points
Ready for takeoff	50 match points

Alliances are seeded in the Qualification tournament using ranking points which are awarded based on a combination of their Win-Loss-Tie record (2 points for a win, 1 point for a tie), the number of times they reach a 40 kiloPascal (kPa) pressure threshold (1 point), and the number of times they start all rotors (1 point).

For full details, read on!

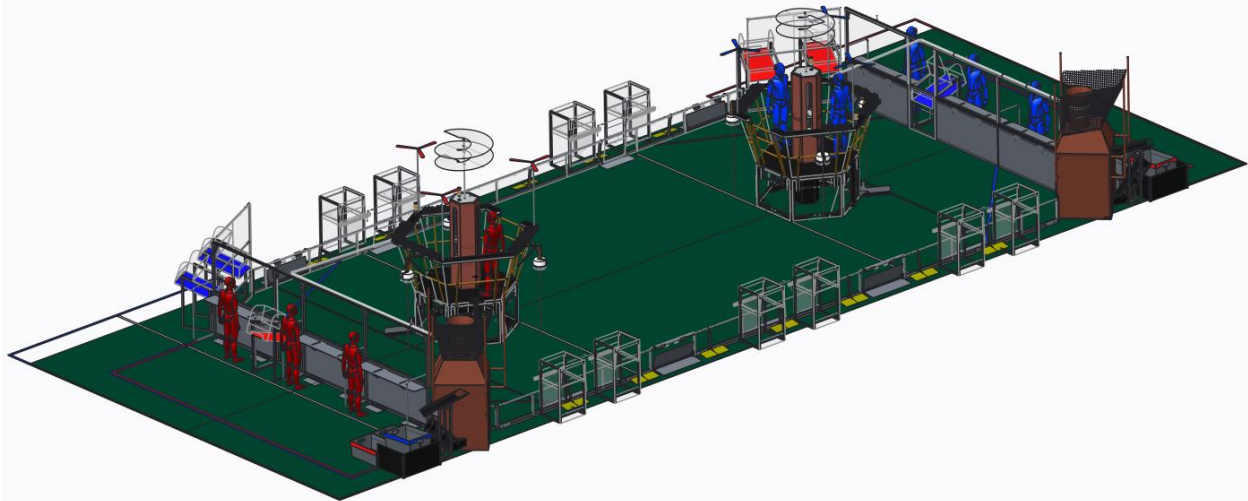




3 ARENA

The ARENA includes all elements and areas of the game infrastructure that are required to play *FIRST STEAMWORKS*SM: the FIELD, AIRSHIPS, carpet, scoring elements, and all equipment and areas needed for FIELD control, ROBOT control, and scorekeeping.

Figure 3-1: *FIRST STEAMWORKS* playing area



The competition ARENA is modular and assembled, used, disassembled, and shipped many times during the competition season. It will undergo wear and tear. The ARENA is designed to withstand rigorous play and frequent shipping. Every effort is made to ensure that ARENAS are consistent from event to event. However, ARENAS are assembled in different venues by different event staff and some small variations occur. For details regarding assembly tolerances, please refer to the [2017 FRC Field Assembly Drawing](#). Successful Teams will design ROBOTS that are insensitive to these variations.

Illustrations included in this section are for a general visual understanding of the *FIRST STEAMWORKS* ARENA, and dimensions included in the manual are nominal. Please refer to the official drawings for exact dimensions, tolerances, and construction details. The official drawings, CAD models, and drawings for low-cost versions of important elements of the *FIRST STEAMWORKS* FIELD are posted in the “Playing Field Details” section of the [FIRST STEAMWORKS Game & Season Materials](#) web page.

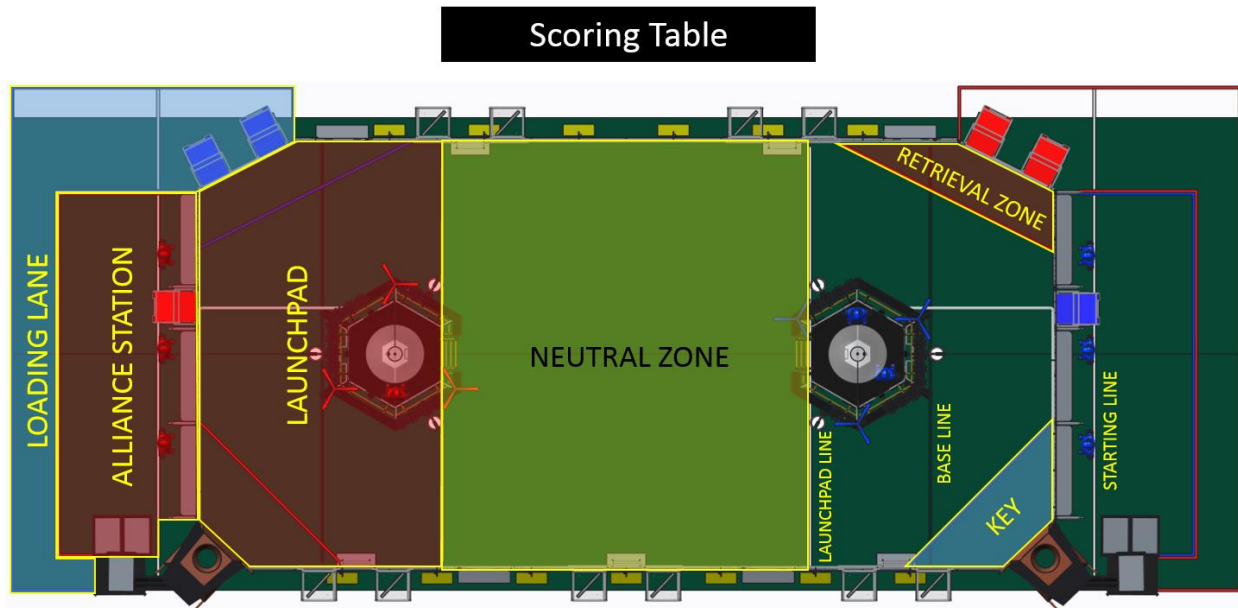




3.1 Zones and Markings

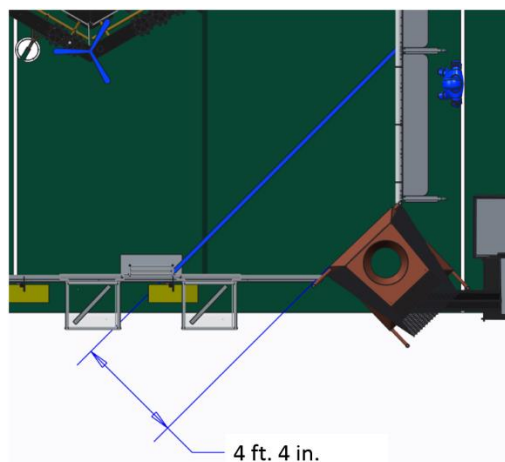
There are several areas on the FIELD relevant to game play and rules. Such spaces are described below. All lines are marked using 2-in. (nominal) gaffers tape.

Figure 3-2: Zones and Markings



- **ALLIANCE STATION:** an 8 ft. 9¾ in. (~269 cm) by 23 ft. 1½ in. (~705 cm) infinitely tall volume bounded by the ALLIANCE WALL and ALLIANCE colored tape. The volume above the tape is part of the ALLIANCE STATION.
- **BASE LINE:** a green line that spans the width of the FIELD and is 7 ft. 9¼ in. (~237 cm) from the ALLIANCE WALL diamond plate.
- **KEY:** an infinitely tall volume in the ALLIANCE'S LAUNCHPAD bounded by the ALLIANCE WALL, GUARDRAIL, and ALLIANCE colored tape. The KEY includes the volume above the tape. The far edge of the tape is parallel to and 4 ft. 4 in. (~132 cm) from the front face of the BOILER.

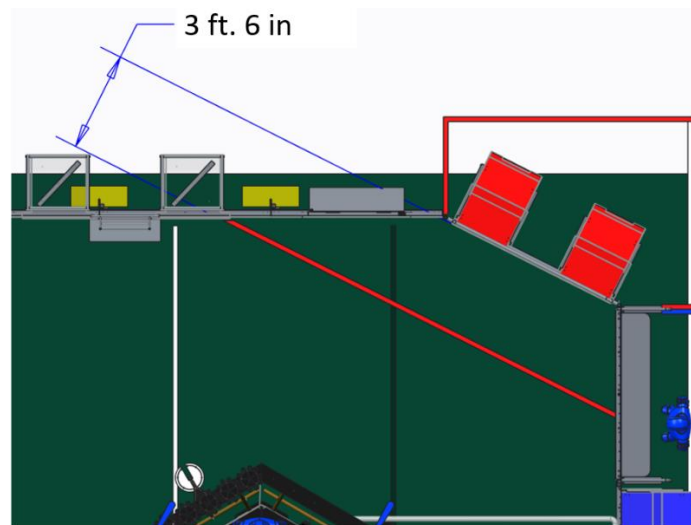
Figure 3-3: KEY





- **LAUNCHPAD:** an infinitely tall volume in the FIELD bounded by the GUARDRAILS, the ALLIANCE WALL, and the LAUNCHPAD LINE. The volume above the LAUNCHPAD LINE is part of the LAUNCHPAD.
- **LAUNCHPAD LINE:** a tape line that is the width of the FIELD and collinear with the edge of the AIRSHIP deck that is closest to the center of the FIELD.
- **LOADING LANE:** an area bounded by and including ALLIANCE colored tape, edge of the carpet, the RETURN BIN Table, and the opponent's ALLIANCE WALL.
- **NEUTRAL ZONE:** an infinitely tall volume on the FIELD bounded by the GUARDRAILS and the LAUNCHPAD LINES. The volume above the LAUNCHPAD LINES is not part of the NEUTRAL ZONE.
- **RETRIEVAL ZONE:** an infinitely tall volume inside the FIELD bounded by the ALLIANCE WALL, GUARDRAIL and ALLIANCE colored tape. The RETRIEVAL ZONE includes the volume above the tape. The far edge of the tape is parallel to and 3 ft. 6 in. (~107 cm) from the front face of the LOADING STATION.

Figure 3-4: RETRIEVAL ZONE



- **STARTING LINE:** a white tape line that runs the width of the carpet and is 2 ft. 6 in. (~76 cm) behind the ALLIANCE WALL diamond plate.

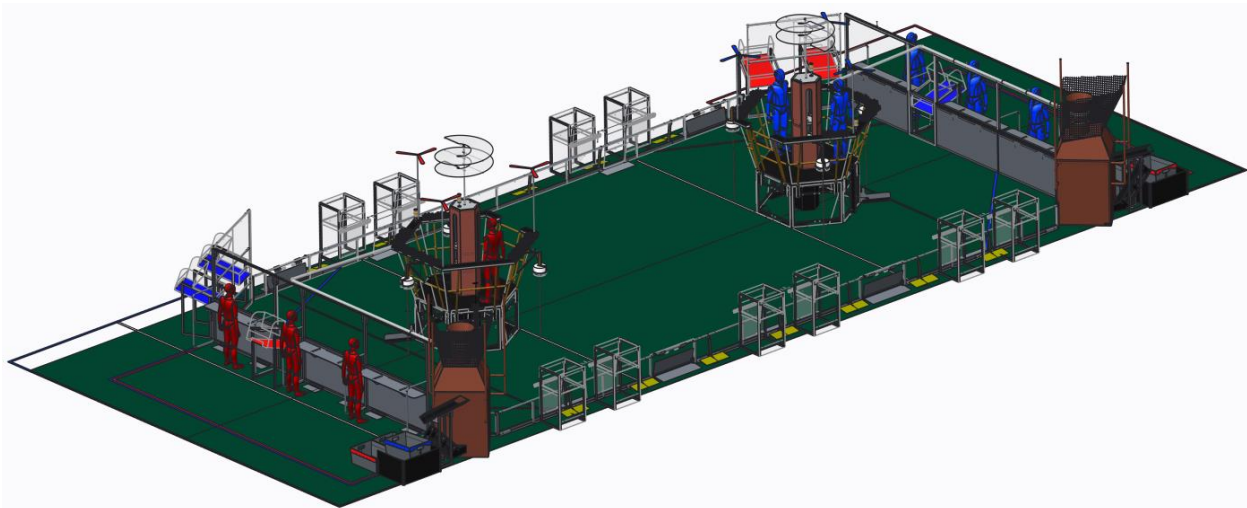




3.2 FIELD

The FIELD for *FIRST STEAMWORKS* is a 27 ft. by 54 ft. 4 in. (~823 cm by ~1656 cm) area, bounded by and including the upward- and inward-facing surfaces of the GUARDRAILS and ALLIANCE WALLS. The carpet used for the FIELD is green (Shaw Floors, Philadelphia Commercial, Neyland II 20, 30352, “Scotch Pine”).

Figure 3-5: *FIRST STEAMWORKS* playing area



There are two versions of GUARDRAILS and PLAYER STATIONS (i.e. the FIELD perimeter) used for competitions. One design has been used at *FIRST* Robotics Competition events for several years and is depicted in the [2017 Basic Field Drawings](#) and *FIRST* provided CAD models. The other is designed and sold by AndyMark. While the designs are slightly different, the critical dimensions, performance, and expected user experience between the two is the same. All Regional and Championship assemblies will use the traditional *FIRST* design. Teams may contact their local District leadership for details on which assembly is used by their District. Detailed drawings for the AndyMark design are posted on the [AndyMark](#) website. All illustrations in this document depict the traditional FIELD design.

3.3 GUARDRAIL

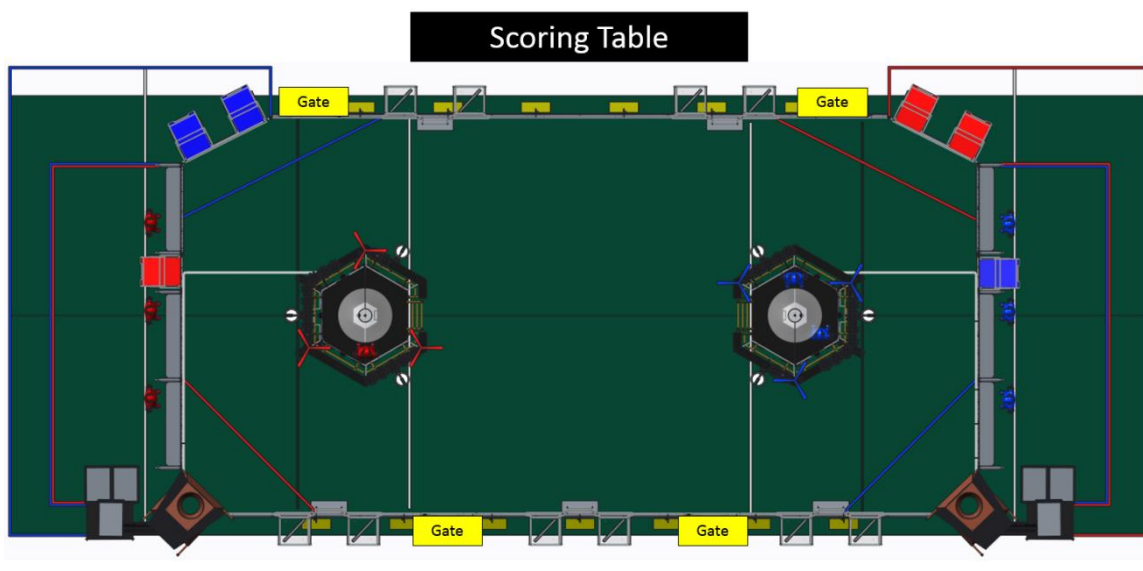
The GUARDRAIL is a system that consists of transparent polycarbonate supported on the top and bottom by aluminum extrusion. The GUARDRAIL prevents ROBOTS from inadvertently exiting the FIELD during a MATCH.

There are four (4) gates in the GUARDRAIL that allow access to the FIELD for placement and removal of ROBOTS. The gates are 3 ft. 2 in. (~97 cm) wide and closed and shielded during the MATCH.





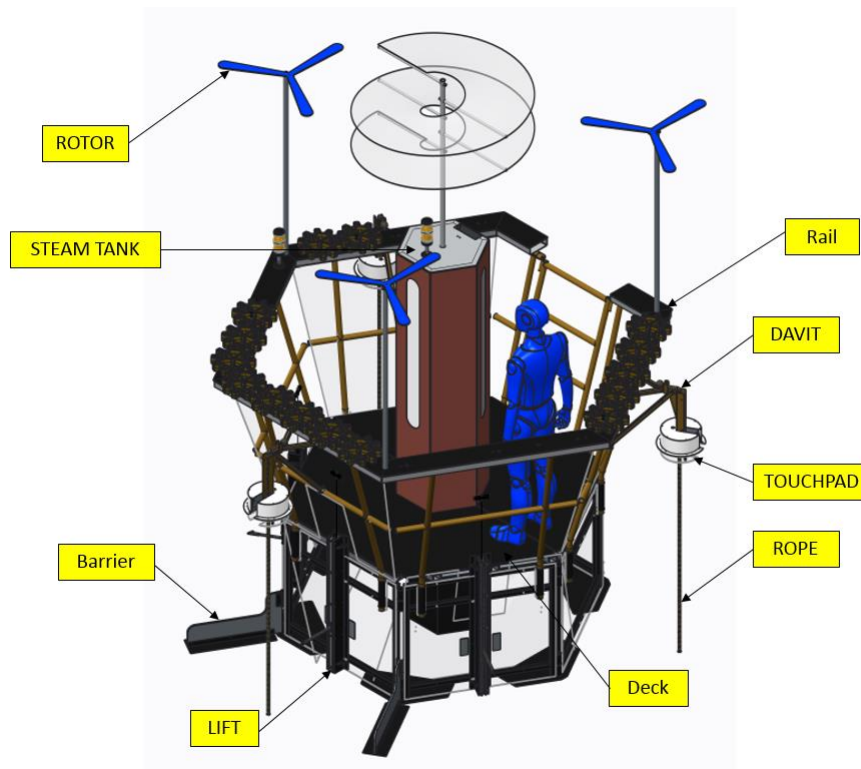
Figure 3-6: Gate locations



3.4 AIRSHIP

The AIRSHIP is a structure that features an elevated hexagonal deck, slanted walls, rails with AXLES to mount GEARS, four (4) ROTORS, three (3) LIFTS, a STEAM TANK, and three (3) ROPES attached to DAVITS. There is one AIRSHIP at the edge of each LAUNCHPAD. The AIRSHIP is positioned such that the three (3) LIFTS face the ALLIANCE WALL.

Figure 3-7: AIRSHIP elements





The hexagonal deck is 5 ft. 10½ in. (~179 cm) wide and 3 ft. ½ in. (~93 cm) above the FIELD carpet. The rail forms an 8 ft. 5 in. (~257 cm) wide hexagon that is 3 ft. 6½ in. (~108 cm) above the deck. Polycarbonate walls connect the deck and rail and angle out from the deck at a 75 deg. angle. PORTS, 13 in. (~33 cm) wide by 19½ in. (~50 cm) holes next to each LIFT, are cut in the three walls facing the ALLIANCE WALL.

Figure 3-8: PORT

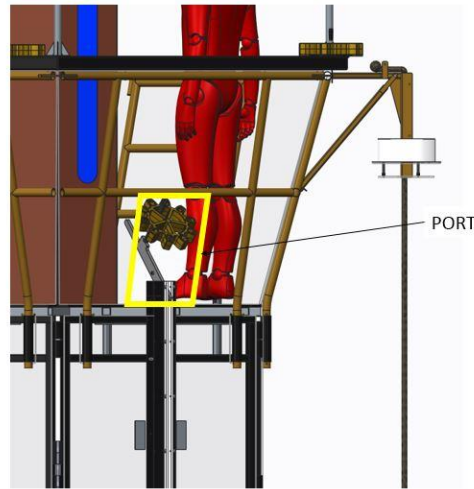
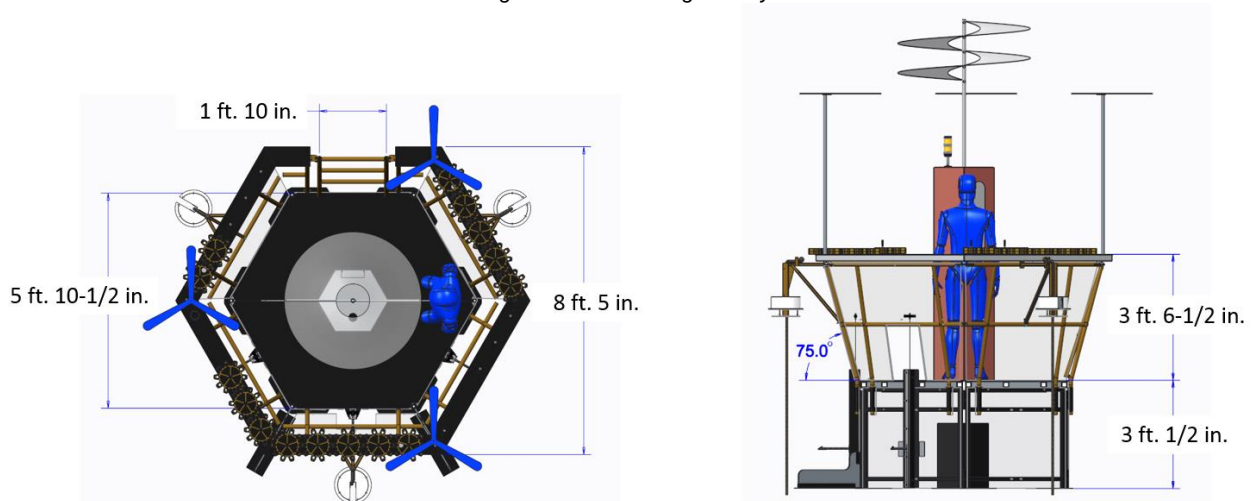


Figure 3-9: AIRSHIP geometry



The deck is accessed by a step ladder. The step ladder is 1 ft. 10 in. (~56 cm) wide. Before MATCH play, it is rotated upward and latched to the rail.

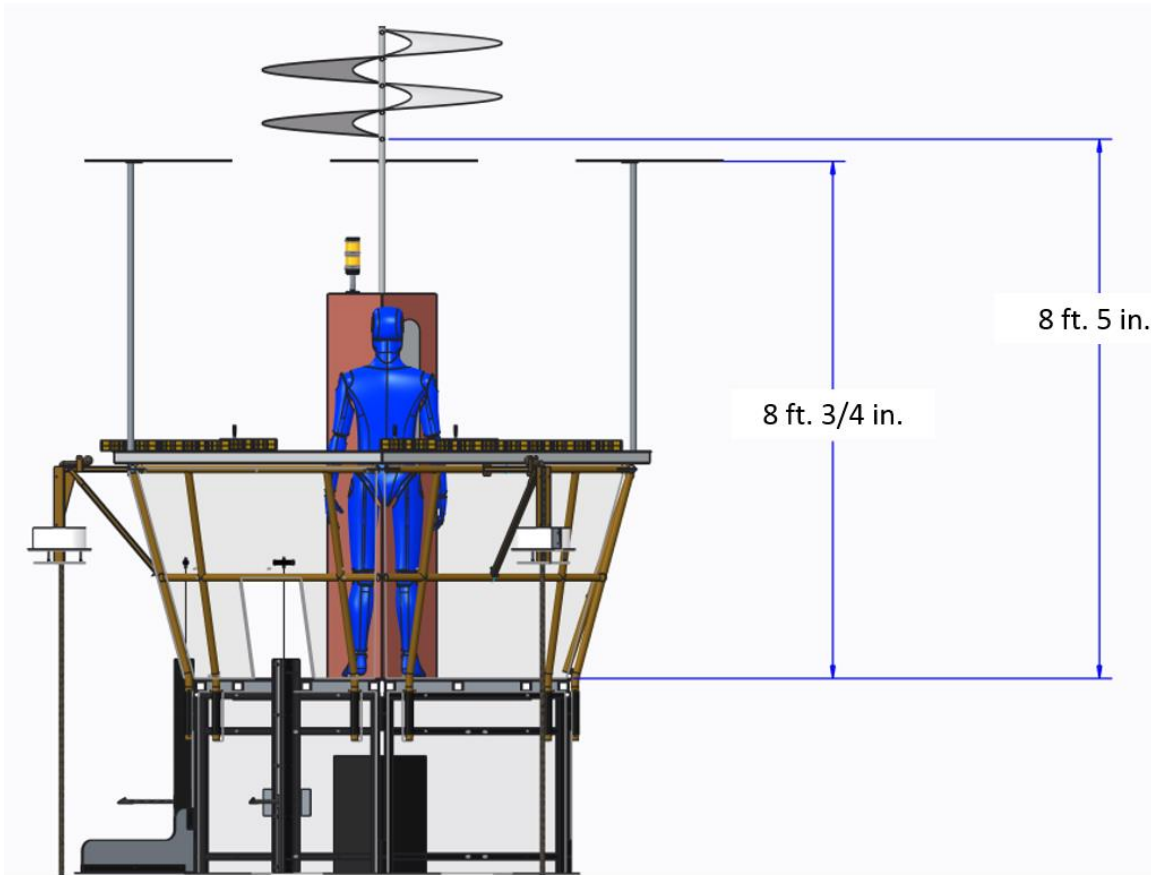
3.4.1 ROTORS

A ROTOR is one of four (4) rotating airfoils mounted to each AIRSHIP. There is one (1) central ROTOR (modeled after the Da Vinci Aerial Screw) that protrudes from the center of the STEAM TANK. It starts 8 ft. 5 in. (~257 cm) above the deck. Three (3) smaller ROTORS are mounted to the rail, 8 ft. ¾ in. (~246 cm) above the deck, and evenly spaced around the rail.





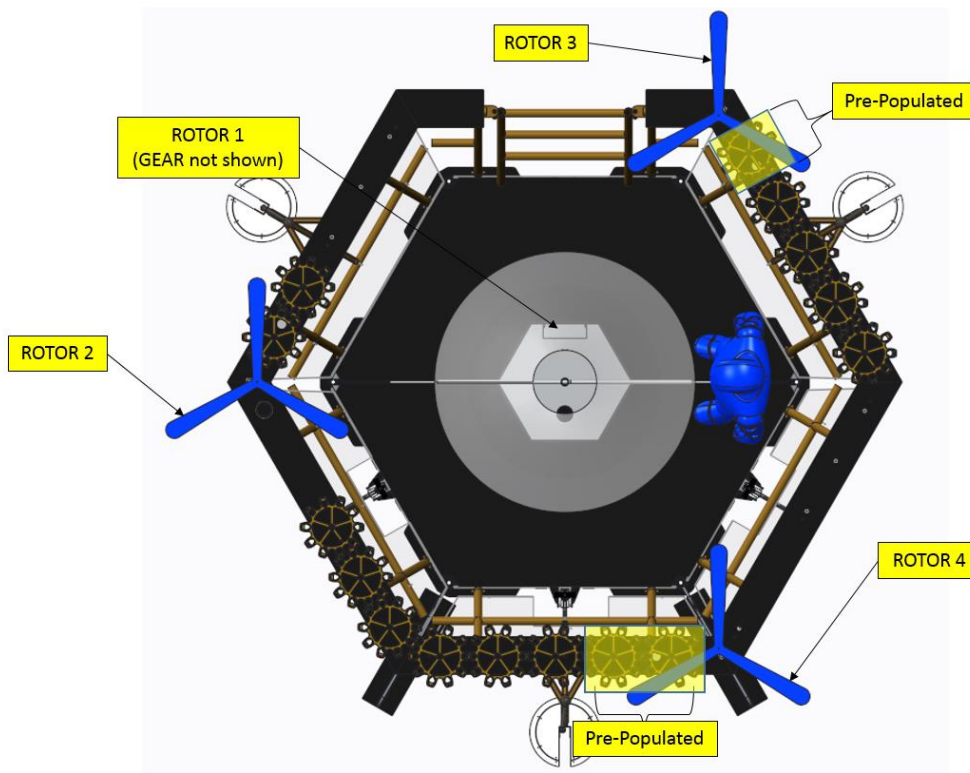
Figure 3-10: ROTOR heights





3.4.2 GEAR Sets

Figure 3-11: GEAR placement



A GEAR set is a series of meshed GEARS that correspond to a specific ROTOR. GEAR sets are installed on AXLES mounted to the rail. An AXLE is a $\frac{7}{8}$ -in. diameter (~2 cm), 2-in. (~5 cm) long shaft which fits the central hub of a GEAR. The number of AXLES for each GEAR set depends on the ROTOR. Some AXLES are prepopulated with GEARS and indicated in Table 3-1. The number of pre-populated GEARS may change for District Championships or the *FIRST* Championship.

Table 3-1: GEAR set population.

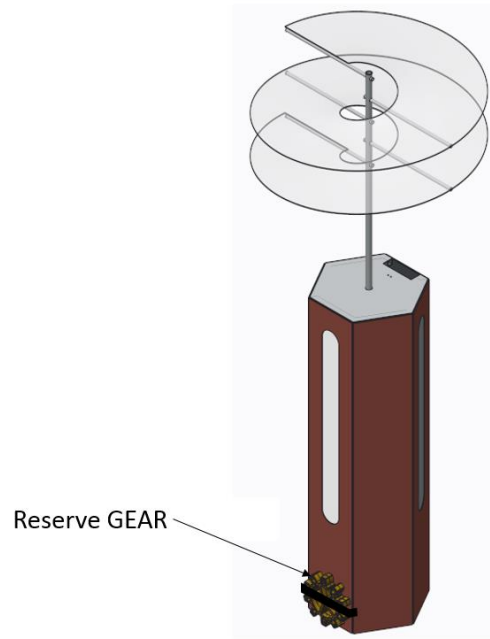
	ROTOR 1	ROTOR 2	ROTOR 3	ROTOR 4
Pre-populated GEARS	0	0	1	2
PILOT placed GEARS	1	2	4	6

One GEAR, the Reserve GEAR, is staged on the AIRSHIP at the start of the MATCH at the base of the STEAM TANK, as shown in Figure 3-12.



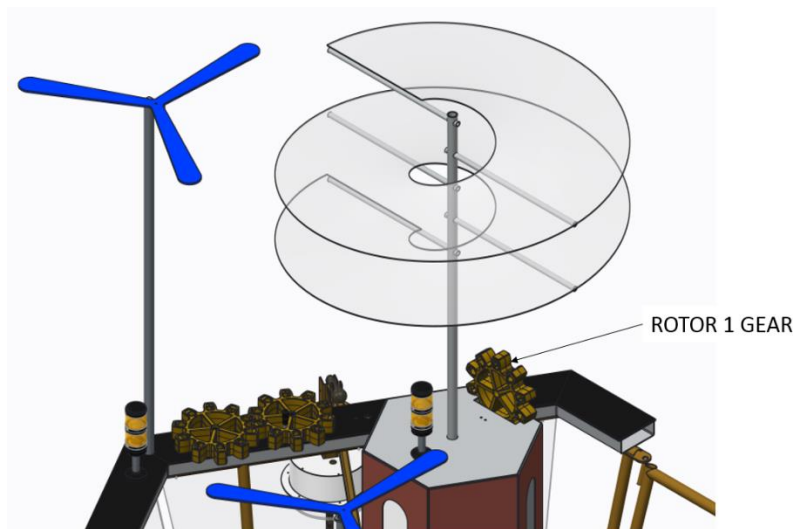


Figure 3-12: Reserve GEAR location



Once a ROTOR is started, it remains turning for the duration of the MATCH. ROTORS only start if GEARS are installed in ROTOR order: 1, 2, 3, and then 4. The order of GEAR placement within a ROTOR set is not important. To start ROTOR 1, the PILOT places the GEAR in the GEAR slot at the top of the STEAM TANK, opposite the stack light for ROTOR 1.

Figure 3-13: GEAR placement to start ROTOR 1



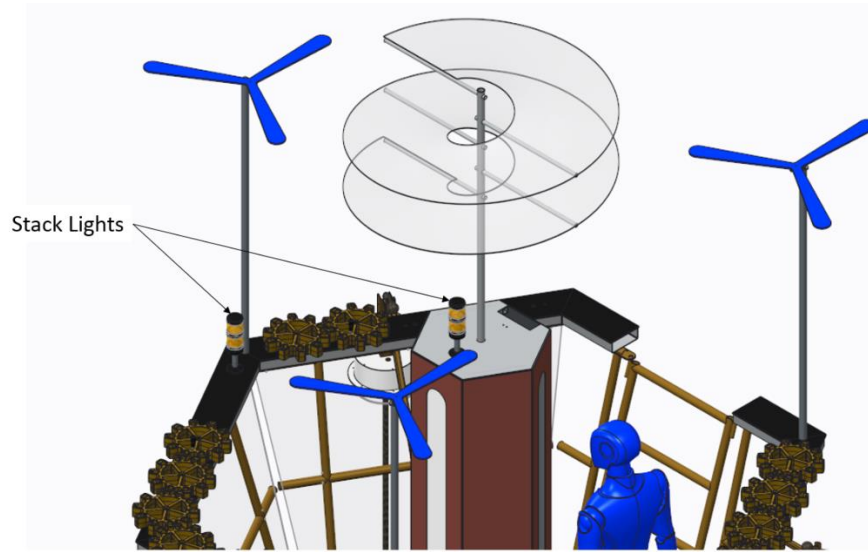
When a GEAR set for ROTORS 2, 3, or 4 is complete, a CRANK, a handle located with the first GEAR in the set, can be turned which engages the corresponding ROTOR. It takes three (3) full rotations to engage the ROTOR.

A yellow stack light is installed next to ROTORS 1 and 2 and illuminates if its corresponding ROTOR is engaged during AUTO.





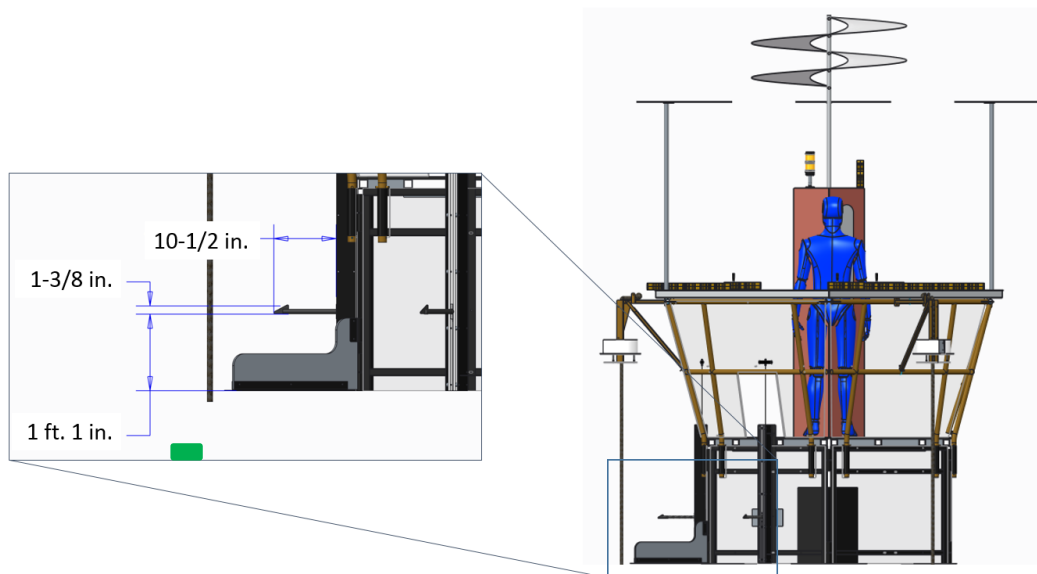
Figure 3-14: AUTO stack light indicators



3.5 LIFTS

LIFTS are used to transfer GEARS from the ROBOTS to the PILOTS. One (1) LIFT is mounted to each of the three (3) sides of the deck that face the PLAYER STATIONS. Each LIFT consists of a peg, steel guide frame, carriage assembly, and cable. The cable is pulled by the PILOT to raise the carriage to a PORT where the GEAR can be safely accessed. Each carriage has a peg designed to hold the GEAR during the transition. The peg is 1 ft. 1 in. (~33 cm) from the FIELD carpet when the carriage is all the way down, protrudes 10½ in. (~27 cm) from the carriage and is 1¾ in. (~3 cm) wide. It is constructed from ⅞-in. (nominal) diameter extension spring (McMaster P/N: [9664K68](#)).

Figure 3-15: LIFT geometry

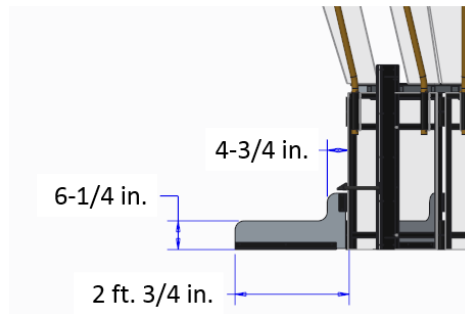


The center LIFT is flanked by two ½-in. (nominal) thick HDPE barriers that radiate out from the adjacent AIRSHIP corners. Barriers are 6¼ in. (~16 cm) tall and extend 2 ft. ¾ in. (~63 cm) out from the leg of the AIRSHIP.





Figure 3-16: Barrier geometry

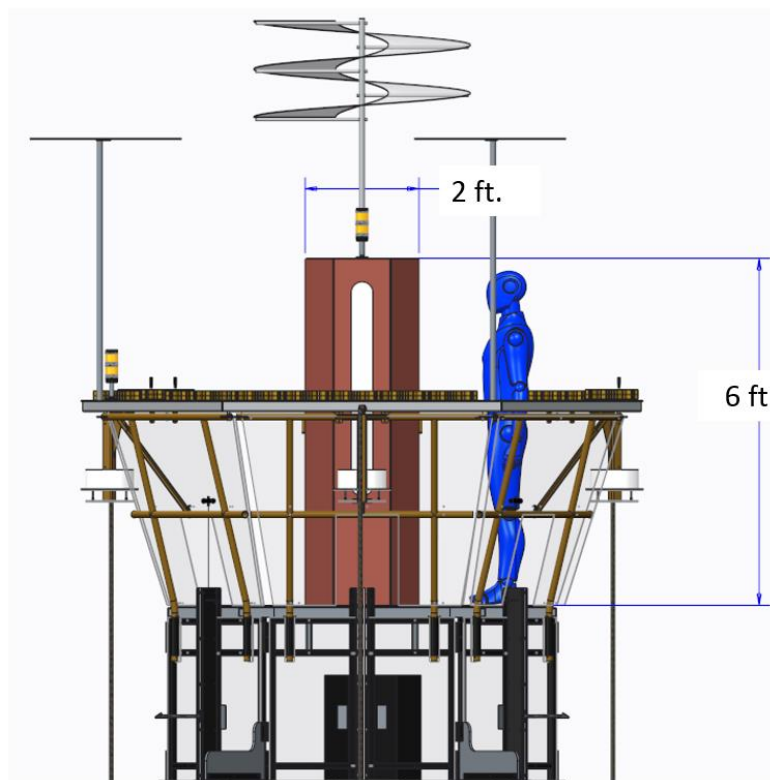


3.6 STEAM TANK

The STEAM TANK is a 6-ft. (~183 cm) tall hexagonal container with a diagonal dimension of 2 ft. (~61 cm) centrally mounted on the deck. It is “filled” via a STEAM PIPE that originates at the BOILERS. Lights indicate the pressure, in kiloPascals (kPa), that’s been generated by the ALLIANCE and stored in the STEAM TANK.

Three windows in the STEAM TANK contain Philips Color Kinetics LED Light Strips used to indicate the amount of steam pressure generated by the BOILER and transmitted to the AIRSHIP. Each window displays the same information. Each row of two (2) LEDs changes, from off to on in white, then from on in white to on in the ALLIANCE color, for each ten (10) kPa of pressure generated. For example, if an ALLIANCE generates ten (10) kPa of pressure, the bottom row is white. If the Red ALLIANCE has generated 20 (twenty) kPa, the bottom LEDs are Red. If the Blue ALLIANCE generates thirty (30) kPa, the bottom row is blue and the second row is white.

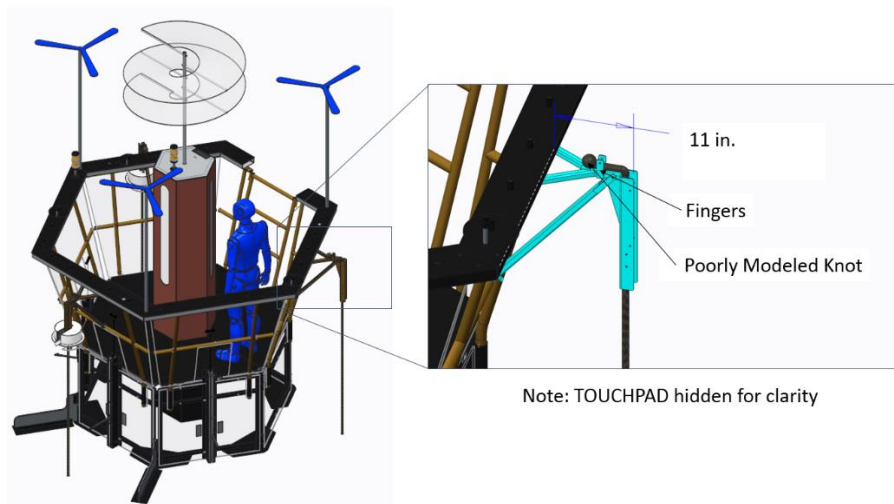
Figure 3-17: STEAM TANK geometry



3.7 DAVIT

A DAVIT is one of three steel frames that attaches a ROPE to the AIRSHIP. Each DAVIT extends 11 in. (~28 cm) from the railing of the AIRSHIP. Each DAVIT has a 2-in. (~5 cm) wide by 2-in. (~5 cm) deep vertical steel channel used to cradle the ROPE and to mount the TOUCHPAD. There are two (2) steel fingers at the top of each DAVIT used to secure the ROPE. These fingers are 1¼ in. (~3 cm) apart and have a hole for a locking pin. The ROPE passes through the fingers with the top knot on the AIRSHIP side of the fingers.

Figure 3-18: DAVIT location and geometry



3.8 ROPE

A ROPE is a strong, thick string composed of twisted or braided strands of manila, hemp, flax, or the like, secured to the AIRSHIP, and used to secure ROBOTS for flight at the end of the MATCH. As described in [Section 4.2 Match Setup](#), Teams are invited to bring and install their own ROPE. If they don't, they can expect default FIELD ROPES installed. These default ROPES are three (3), 1 in. (nominal) thick by 7 ft. 2 in. (~218 cm) long polypropylene "Manila" style ROPES from Knot and Rope Supply, [SKU 0162](#). Each default ROPE is knotted at the top, fused at the bottom, suspended from a notch at the end of each DAVIT, and coiled and stowed on the outside of the AIRSHIP. The ROPE passes through the center of the TOUCHPAD and hangs down to the FIELD carpet. The PILOT pulls the ROPE'S retention strap to deploy the ROPE.

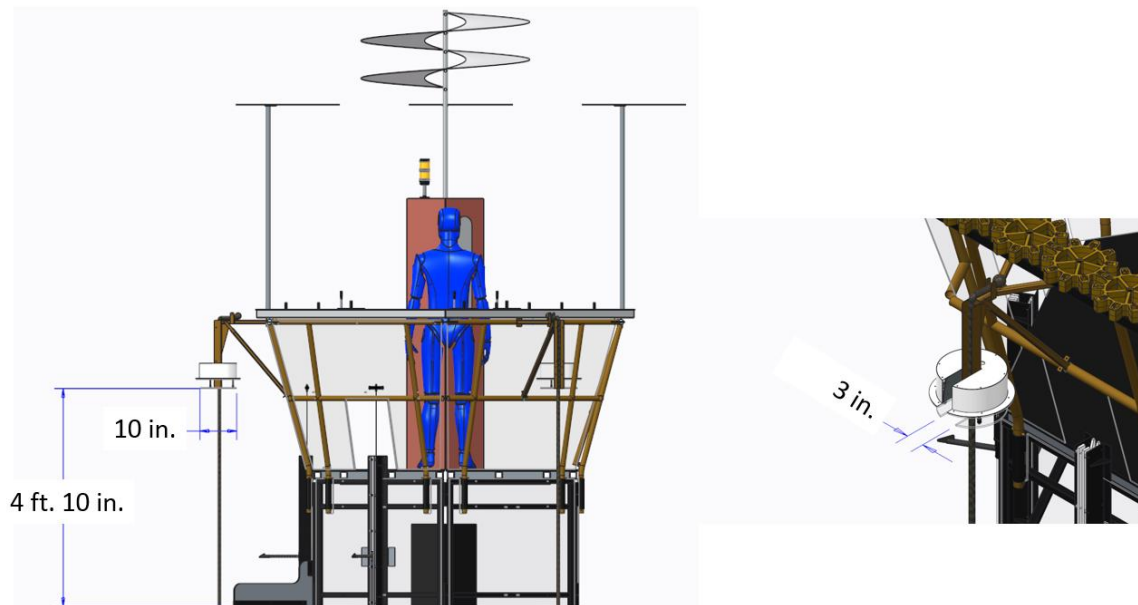
3.9 TOUCHPAD

Each TOUCHPAD is a 10 in. (~25 cm) polycarbonate plate mounted 4 ft. 10 in. (~147 cm) above the carpet and used to determine if a ROBOT has successfully latched on to the AIRSHIP (i.e. ready for takeoff) at the end of the MATCH. The plate has a 3 in. (~8 cm) wide by 6 in. (~15 cm) deep rectangular cut-out to aid in assembly and ROPE mounting.





Figure 3-19: TOUCHPAD geometry



The TOUCHPAD plate must be pressed such that the following conditions are met for the ROBOT to be credited with being ready for takeoff at the end of the MATCH:

- A. it's minimally displaced by $\frac{1}{2}$ in. (~1 cm),
- B. it's pressed for a duration of at least one (1) sec, and
- C. it's pressed when the Teleop Period ends at $T = 0$

The force required to activate the TOUCHPAD (i.e. push the TOUCHPAD plate up by approximately $\frac{1}{2}$ in. (~1.3 cm), causing activation of one or more of its microswitches) is no more than 2 lbs. (~0.9 kg)

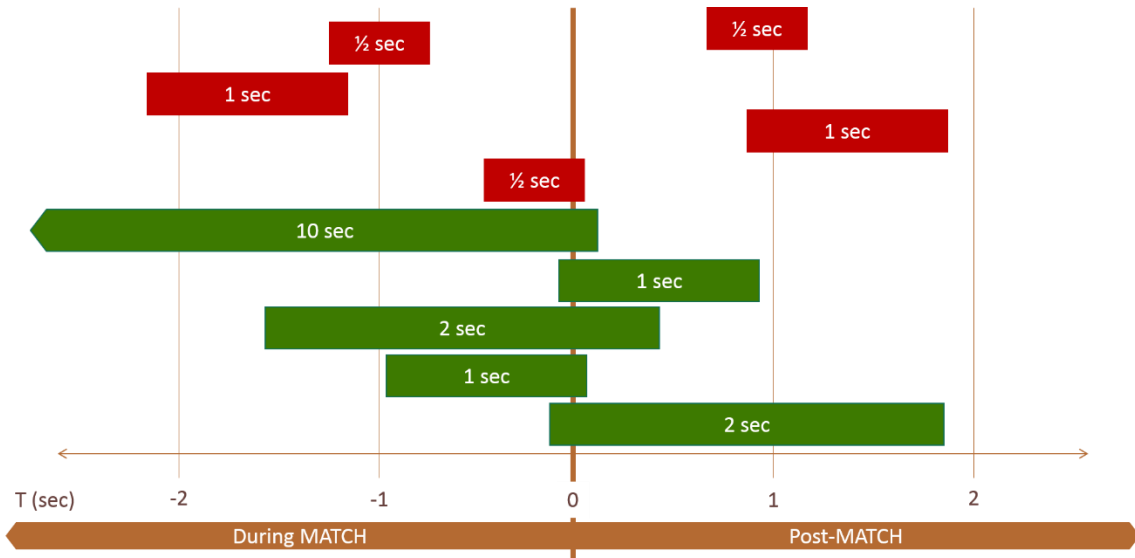
The force required to move the TOUCHPAD throughout its full range of travel (i.e. cause the TOUCHPAD plate to travel the full $1\frac{1}{2}$ in. (~4 cm)) is no more than 2 lbs. (~0.9 kg).

Teams may wish to consider a reasonable "safety factor" for TOUCHPAD activation and assume that no more than 3 lbs. (~1.4 kg) of vertical force is required to guarantee activation to account for tolerances, assembly variations, temperature/humidity differences, and other variances.

Figure 3-20 shows examples where the TOUCHPAD has been sufficiently displaced, but timing varies. Activations in red indicate that the requirements were not met, and the ROBOT was not credited with "ready for takeoff" points defined in Table 4-1. Activations in green meet all criteria and credit the ALLIANCE with associated points.

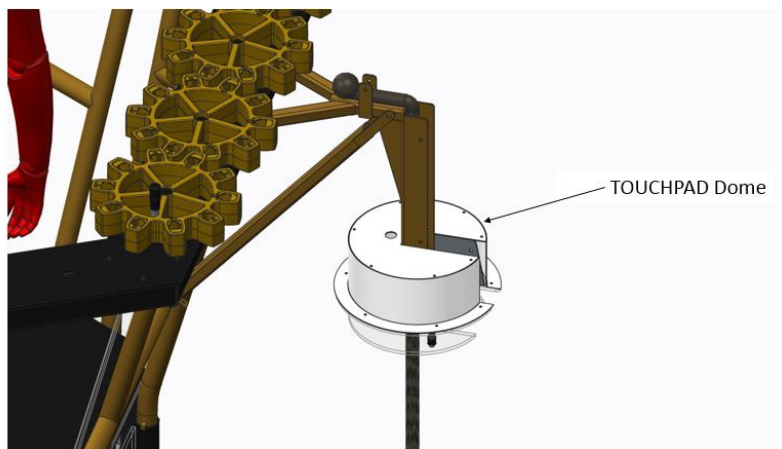


Figure 3-20: TOUCHPAD activation examples.



A plastic dome is mounted above each TOUCHPAD and indicates if the associated ROBOT is ready for takeoff. When thirty (30) seconds remain in TELEOP, all six (6) domes briefly animate to indicate that they are active. If a TOUCHPAD is pressed by a ROBOT prior to this, the dome remains off. If a TOUCHPAD is pressed during the final thirty (30) seconds of the MATCH and for the minimal duration described in part B above, the dome illuminates in the ALLIANCE'S color and the associated points are added to the real-time score. If a ROBOT causes a dome to illuminate, but disengages from the TOUCHPAD, the dome turns off and the associated points are removed from the real-time score.

Figure 3-21: TOUCHPAD dome



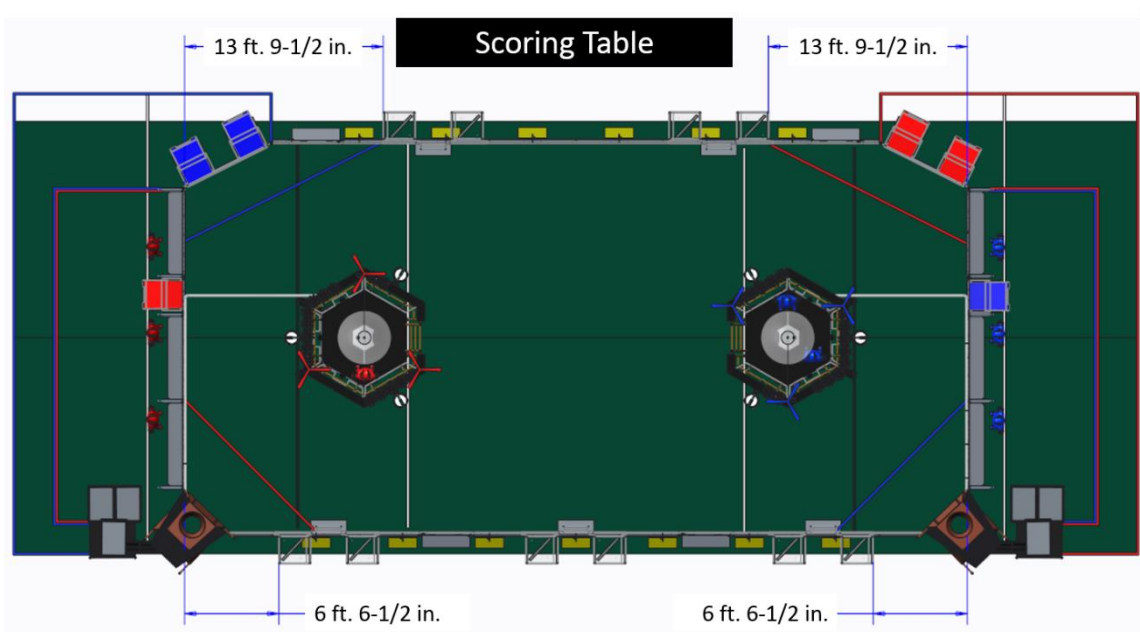
3.10 HOPPERS

A HOPPER is a pair of containers located just outside the FIELD and used to store FUEL at the start of the MATCH. There are five (5) HOPPERS located alongside and outside the GUARDRAIL. Two (2) are positioned on the scoring table side of the FIELD and are each 13 ft. 9½ in. (~420 cm) from the ALLIANCE WALLS. Two (2) are positioned opposite the scoring table side of the FIELD and are each 6 ft. 6½ in. (~199 cm) from the ALLIANCE WALLS. The fifth HOPPER is positioned opposite the scoring table side of the FIELD and centered on the GUARDRAIL.



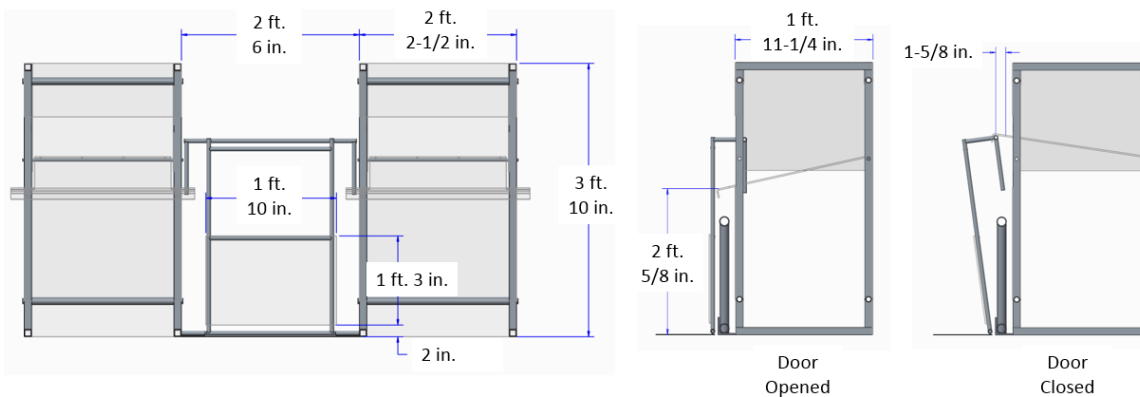


Figure 3-22: HOPPER locations



Each HOPPER container is an aluminum framed polycarbonate box that is 2 ft. 2½ in. (~67 cm) wide by 1 ft. 11¼ in. (~59 cm) deep by 3 ft. 10 in. (~117 cm) high. There is an opening that faces the FIELD at the top of each HOPPER container. Once a polycarbonate panel is pushed, the floor of the box pivots down, causing FUEL to roll onto the FIELD. When depositing FUEL onto the FIELD, the floor of the HOPPER is 2 ft. ⅝ in. (~63 cm) from the carpet. The polycarbonate panel is 1 ft. 3 in. (~38 cm) high, 1 ft. 10 in. (~56 cm) long and 2 in. (~5 cm) above the FIELD carpet, and requires approximately 25 lbs. (~11 kg) applied 6 in. from the carpet over 1⅝ in. (~4 cm) toward the HOPPER (until flush with the guardrail) to fully engage.

Figure 3-23: HOPPER geometry

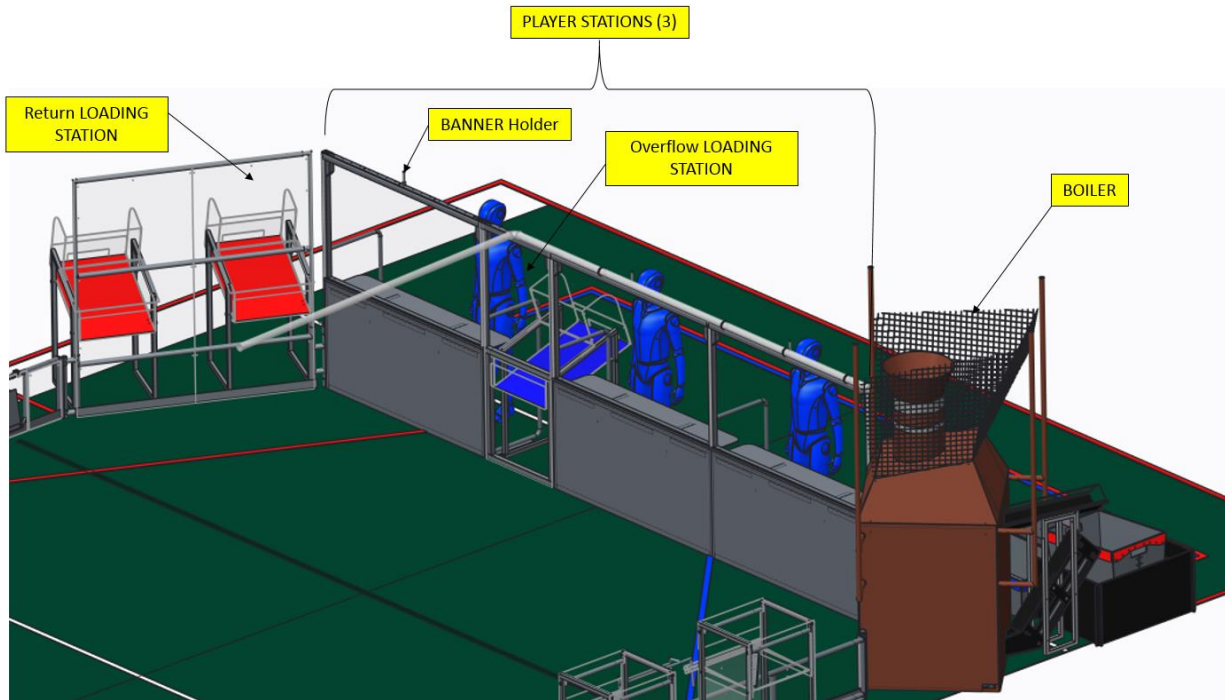




3.II ALLIANCE WALL

The ALLIANCE WALL is the physical structure that separates ROBOTS from DRIVE TEAMS (except the PILOT) and consists of a BOILER, three (3) PLAYER STATIONS, an Overflow LOADING STATION and a Return LOADING STATION.

Figure 3-24: ALLIANCE WALL COMPONENTS



3.II.I PLAYER STATION

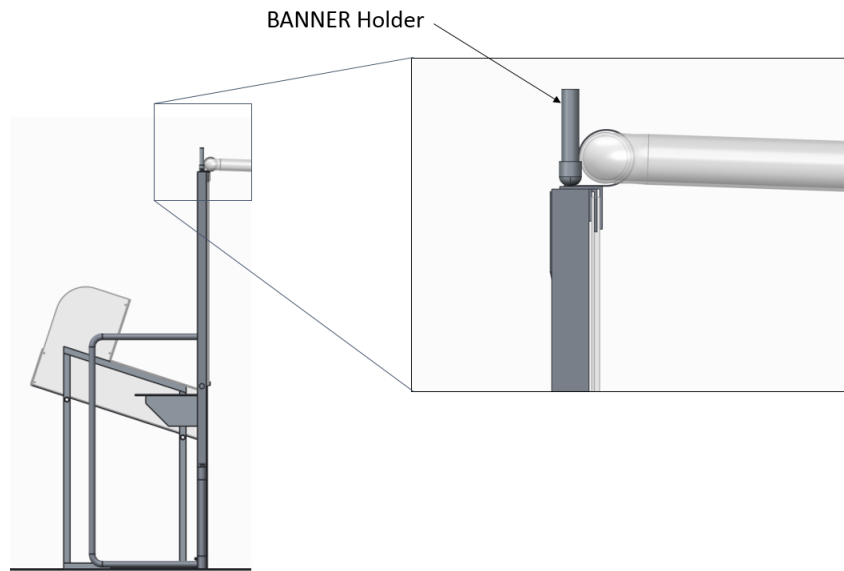
A PLAYER STATION is one (1) of three (3) assigned positions in an ALLIANCE WALL from where a DRIVE TEAM operates their ROBOT. Each PLAYER STATION is made from a 3 ft. (~91 cm) tall diamond plate panel base topped with a 3 ft. 6 in. (~107 cm) tall transparent plastic panel. An aluminum shelf is attached to each PLAYER STATION to support the DRIVE TEAM'S OPERATOR CONSOLE. The shelf is 5 ft. 9 in. (~175 cm) wide and 1 ft. (~30 cm) deep. There is a 4 ft. 6 in. (~137 cm) long by 2 in. (nominal) wide strip of hook-and-loop tape ("loop" side) along the center of the support shelf that may be used to secure the OPERATOR CONSOLE to the shelf.

Each Player Station supports one (1) BANNER Holder. The BANNER Holder features a receptacle designed to hold a ½-in. (nominal) diameter rod and is mounted above the team sign and behind the STEAM PIPE.





Figure 3-25: BANNER holder



Each PLAYER STATION contains the following electronic components for Teams:

- One Ethernet Cable: attaches to the Ethernet port of the OPERATOR CONSOLE and provides connectivity to the ARENA network.
- One 120VAC NEMA 5-15R power outlet: located on the right side of each PLAYER STATION shelf and protected by its own 2-Amp circuit breaker. It can be used to power the OPERATOR CONSOLE. DRIVE TEAMS are responsible for monitoring their power consumption as a tripped breaker in the outlet does not constitute an ARENA fault.

Note: The power outlet circuit breaker has been reduced from a 3A breaker to a 2A breaker (used in 2015 and 2016).

- One Emergency Stop (E-Stop) button: located on the left side of the PLAYER STATION shelf and should be used to deactivate a ROBOT in an emergency.
- One Team sign: displays the Team number and located at the top of each PLAYER STATION.
- One Team LED: indicates ALLIANCE color, ROBOT status, and E-Stop status and centered at the top of each PLAYER STATION. Team LED states include:
 - Solid: indicates that the ROBOT is connected and enabled. This will only happen during a MATCH.
 - Blinking: indicates that either the Field Management System (FMS) is preset for the MATCH or it's during a MATCH and the corresponding ROBOT has lost connectivity.
 - Off: indicates that the MATCH has not started yet, but the ROBOT is linked and disabled.
 - If the amber LED is on, the E-stop button has been pressed.
- One Timer: displays the official time remaining in AUTO, TELEOP, and TIMEOUTS and marked with white tape along the bottom edge. A Timer is positioned at the top of each Return LOADING STATION.
- Competition ARENA hardware and wiring: mostly located below the center PLAYER STATION shelf.

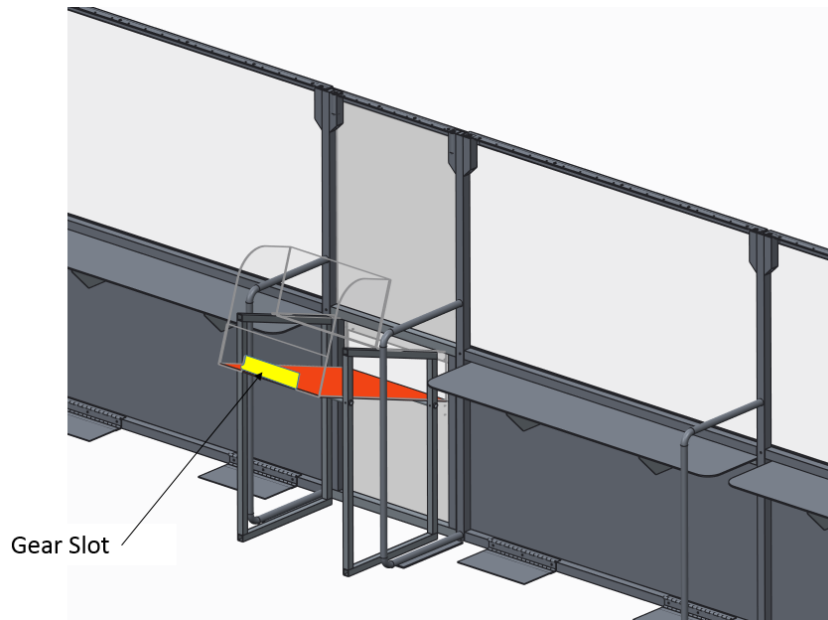




3.II.2 Overflow LOADING STATION

An Overflow LOADING STATION is located two (2) PLAYER STATIONS away from each BOILER.

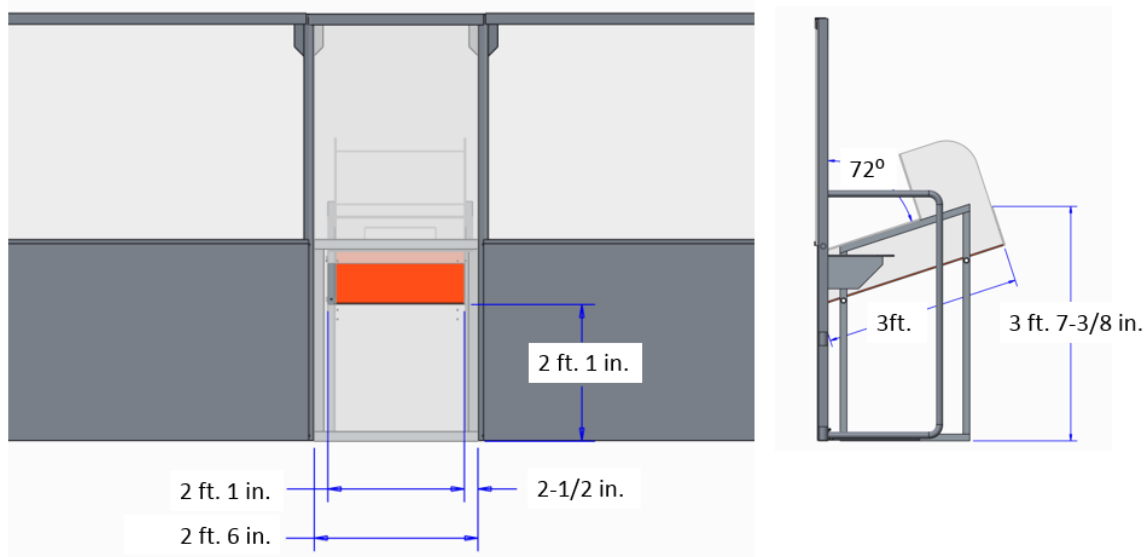
Figure 3-26: Overflow LOADING STATION



An Overflow LOADING STATION is used to feed FUEL from the OVERFLOW BIN on to the FIELD. Each Overflow LOADING STATION includes a 6 ft. 6 in. (~198 cm) in. tall and 2 ft. 6 in. (~76 cm) wide polycarbonate panel with an opening, aluminum frame, and shelf with backboard. The opening is 2½ in. (~6 cm) from each edge of the loading station, 2 ft. 1 in. (~64 cm) wide, 7½ in. tall (~19 cm), and 2 ft. 1 in. (~64 cm) above the carpet.

The Overflow LOADING STATION shelf is 2 ft. 1 in. (~64 cm) wide, 3 ft. (~91 cm) long, and mounted at a 72 deg. angle. The top of the shelf is 3 ft. 7⅜ in. (~110 cm) from the carpet.

Figure 3-27: Overflow LOADING STATION geometry

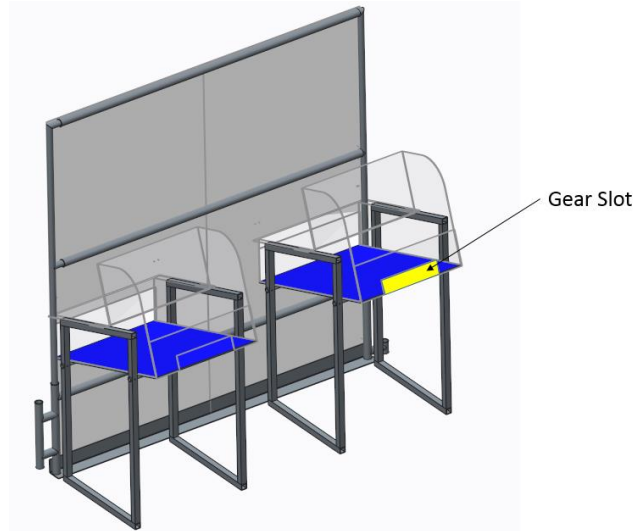




3.II.3 Return LOADING STATIONS

Return LOADING STATIONS are located in each of the two (2) corners of the FIELD opposite the BOILERS.

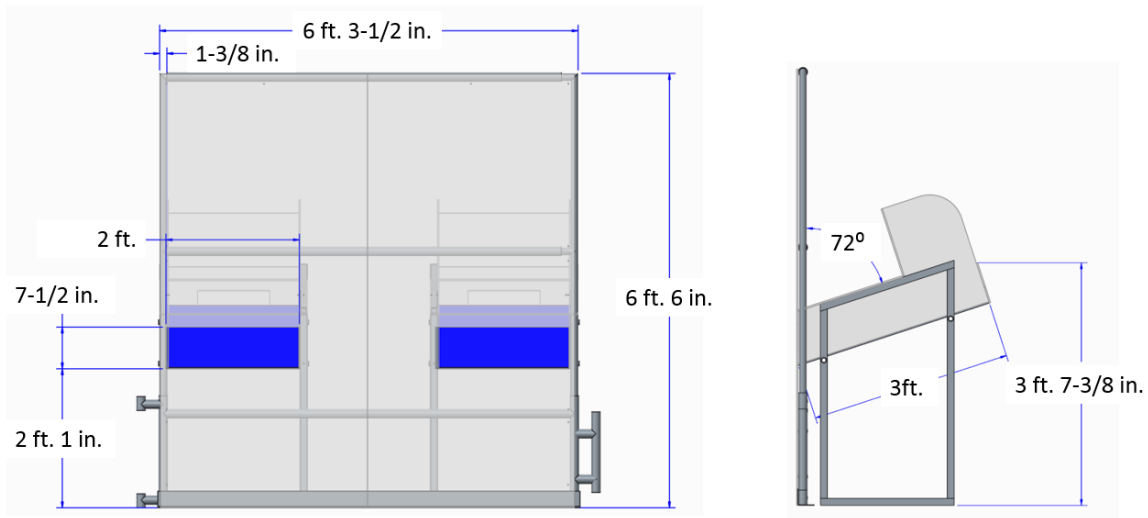
Figure 3-28: Return LOADING STATIONS



A Return LOADING STATION is used to feed FUEL and GEARS on to the FIELD. Each Return LOADING STATION includes a 6 ft. 6 in. (~198 cm) in. tall and 6 ft. 3½ in. (~192 cm) wide polycarbonate panel with two (2) openings, aluminum frame, and shelves with backboards. The openings are side by side, 1⅜ in. (~3 cm) from each edge of the loading station, 2 ft. (~61 cm) wide, 7½ in. tall (~19 cm), and 2 ft. 1 in. (~64 cm) above the carpet.

There are two (2) shelves, 2 ft. (~61 cm) wide by 3 ft. (~91 cm) long, mounted at a 72 deg. angle. The tops of the shelves are 3 ft. 7⅞ in. (~110 cm) from the carpet. Each shelf has a slot through which to pass GEARS.

Figure 3-29: Return LOADING STATION geometry





3.II.4 BOILER

A BOILER is a FIELD element which converts FUEL to steam. There is a BOILER on each corner of the FIELD opposite the scoring table. The base of each BOILER is 3 ft. 6 in. wide (~107 cm) by 3 ft. 6 in. (~107 cm) deep by 8 ft. 1 in. (~246 cm) tall. There are two (2) openings, or GOALS, for loading FUEL into the BOILER: the High Efficiency GOAL and the Low Efficiency GOAL.

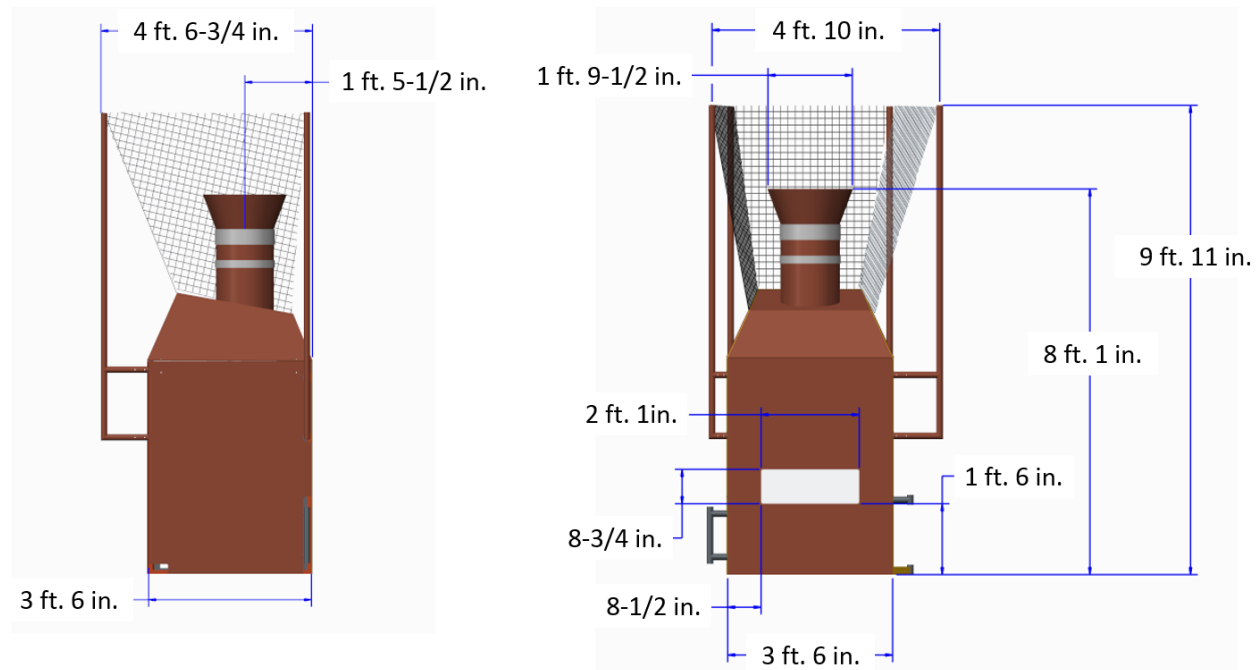
The High Efficiency GOAL is a 1 ft. 9½ in. (~55 cm) diameter vertical cylinder. The opening is 8 ft. 1in. (~246 cm) from the carpet. The horizontal offset between the face of the BOILER and the center of the High Efficiency Goal opening is 1 ft. 5½ in. (~44 cm).

The High Efficiency GOAL geometry can be simulated using six (6) 2015 Recycle Rush™ totes and one (1) 2015 Recycle Rush recycling container.

The Low Efficiency GOAL is 2 ft. 1 in. (~64 cm) wide by 8¾ in. (~22 cm) tall. The bottom edge of the GOAL is 1 ft. 6 in. (46 cm) above the carpet.

A series of nets is installed behind the BOILER which redirects missed shots back in to the FIELD. The net is approximately 4 ft.10 in. (147 cm) wide by 9 ft. 11 in. (302 cm) tall and is set 4 ft. 6¾ in. (139 cm) behind the GOAL opening. Nets are used to retain GAME PIECES in the FIELD and not intended to behave consistently.

Figure 3-30: BOILER geometry



The capacity of the Low Efficiency GOAL is seventy (70) FUEL. The capacity of the High Efficiency GOAL is one-hundred and fifty (150) FUEL. FUEL that exceeds GOAL capacities will fall back on to the FIELD.

A BOILER processes FUEL in to steam at an average rate of five (5) FUEL per second per GOAL, but actual rate is dependent on the amount and packing of FUEL in the GOALS (i.e. the tighter the packing in a GOAL, the faster the FUEL processing rate).





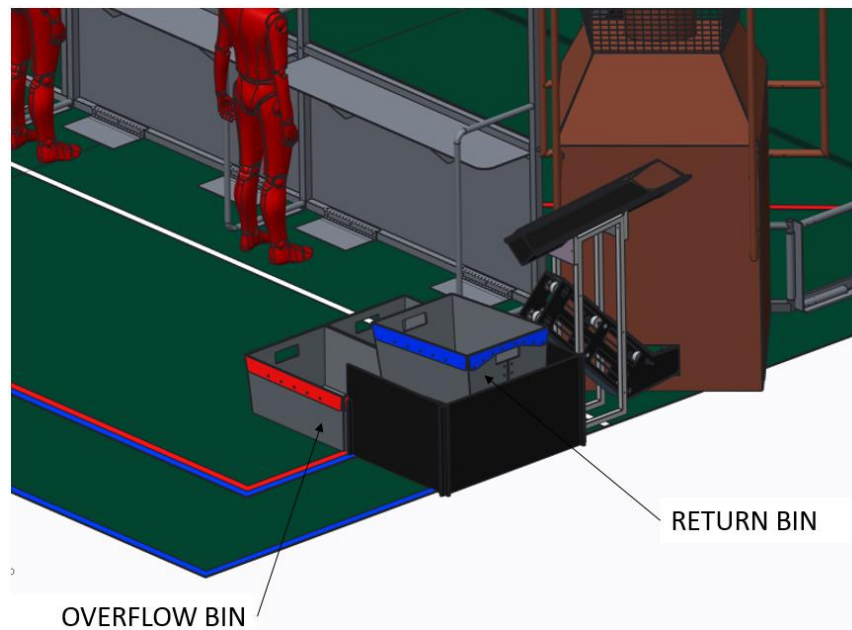
3.II.5 RETURN & OVERFLOW BINS

RETURN and OVERFLOW BINS are used to store and transport FUEL that has exited a BOILER. They are plastic open-topped containers, 2 ft. 9½ in. (~85 cm) wide by 1 ft. 6 in. (~46 cm) deep by 1 ft. 1 in. (~33 cm) tall, and each has a capacity of approximately fifty to sixty (50-60) FUEL.

Once FUEL is processed, it exits the BOILER into a RETURN BIN. Each LOADING LANE has three (3) RETURN BINS. To prevent a RETURN BIN from overflowing, HUMAN PLAYERS may replace it with an empty RETURN BIN.

Should a RETURN BIN overflow, the FUEL collects in either of the (2) OVERFLOW BINS.

Figure 3-31: RETURN and OVERFLOW BINS



3.II.6 STEAM PIPE

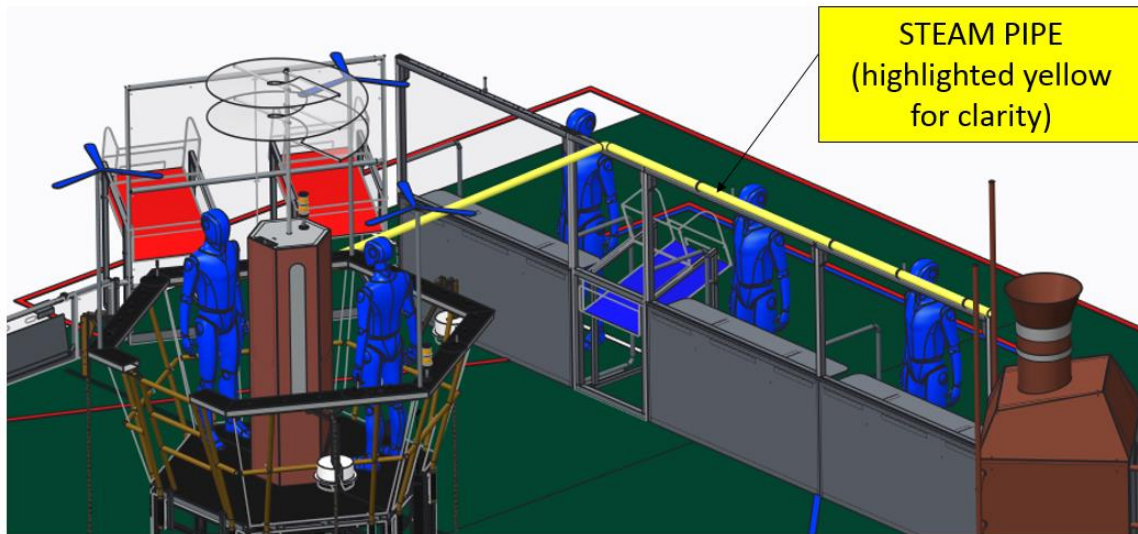
The STEAM PIPE is a clear PVC pipe that transfers steam from the BOILER to the STEAM TANK on the AIRSHIP. It is constructed from 2¾ in. (nominal) diameter clear plastic pipe and exits out the side of the BOILER net support pipe closest to the PLAYER STATION. It is mounted flush to the top of the ALLIANCE WALL and when it reaches the middle of the Overflow LOADING STATION, it turns and extends to the AIRSHIP.

The pipe contains strips of Philips Color Kinetics Lights which display the transfer of steam. A pattern of colored LEDs flow from the BOILER to the AIRSHIP as FUEL is scored by the BOILER. As the rate of FUEL being scored inside the BOILER increases, the animation become faster. If the scoring rate decreases, the animation slows down. If an ALLIANCE stops scoring FUEL in their BOILER, the lights will come to a stop at their current position, indicating that FUEL is not being scored.





Figure 3-32: STEAM PIPE



3.12 GAME PIECES

3.12.1 FUEL

FUEL is used to generate steam for the AIRSHIP and is represented by "[Screamin' Yellow,](#)" 5 in. (nominal) diameter Gopher ResisDent™ polyethylene balls (Item Number 42-555). Each FUEL weighs 2.6 oz. (~74 g.). FUEL may be purchased from AndyMark (am-3376), and a six (6) pack of balls may be purchased directly from Gopher Sports.

Figure 3-33: FUEL



3.12.2 GEARS

A GEAR is a toothed wheel used to start ROTORS on the AIRSHIP. Each GEAR is made from gold (Pantone PMC 124C) polypropylene, has 10 teeth, an 11 in. (~28 cm) diameter, 10 in. (~25 cm) pitch diameter, and is 2 in. (~5 cm) thick. Each GEAR weighs 18.4 oz. (~0.5 kg.) GEARS may be purchased from AndyMark (am-3302).

Figure 3-34: GEAR



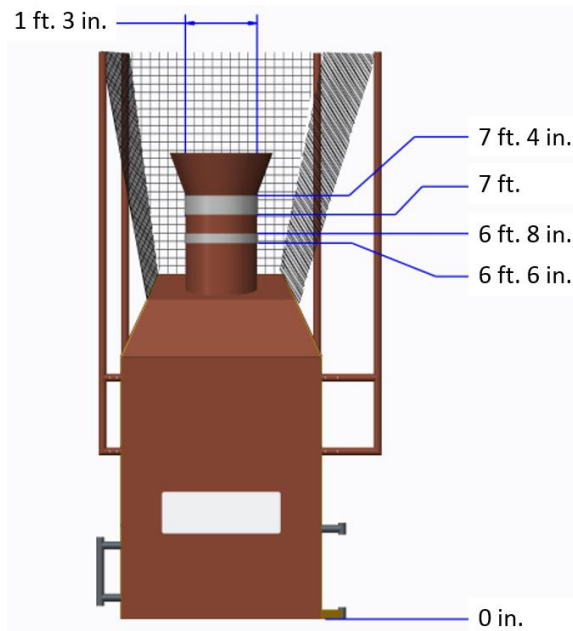


3.13 Vision Targets

Vision targets are marked using [3M 8830 Scotchlite Reflective Material](#) and highlight the locations of High GOALS and LIFT pegs.

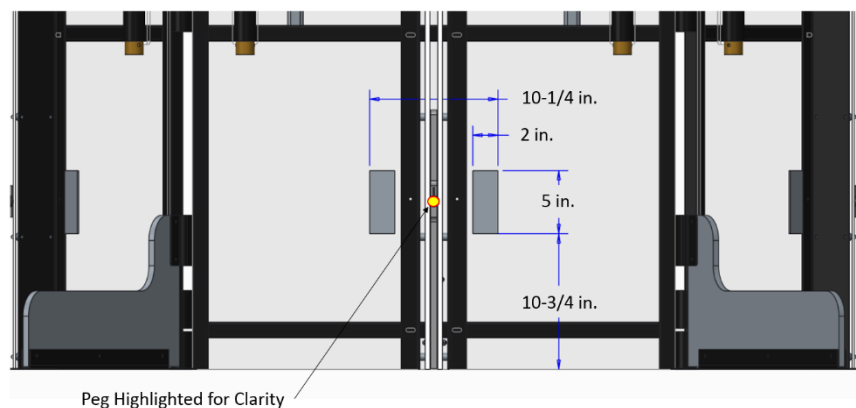
The vision target on the High GOAL consists of two horizontal rings. The first ring is 4 in. (~10 cm) wide, with the upper edge located 7 ft. 4 in. (~224 cm) from the carpet. The second ring is 2 in. (~5 cm) wide with the upper edge 6 ft. 8 in. (~203 cm) off the carpet.

Figure 3-35: BOILER vision target measurements



There are also vision targets on both sides of each LIFT peg. The peg targets are 2 in. (~5 cm) wide by 5 in. (~13 cm) tall rectangles located 10 $\frac{1}{4}$ in. (~27 cm) from the carpet and spaced 10 $\frac{1}{4}$ in. (~26 cm) apart (outside dimensions).

Figure 3-36: LIFT peg vision target dimensions



3.14 The Field Management System

When a DRIVE TEAM connects the Ethernet cable from their assigned PLAYER STATION to their OPERATOR CONSOLE, the Driver Station software on the OPERATOR CONSOLE computer will begin





to communicate with the Field Management System (FMS). Once connected to FMS, the only open ports available are described in Table 3-2.

Table 3-2: Open FMS Ports

Port	Designation	Bi-directional?
UDP/TCP 1180-1190	Camera data from the roboRIO to the Driver Station (DS) when the camera is connected to the roboRIO via USB	Yes
TCP 1735	SmartDashboard	Yes
UDP 1130	Dashboard-to-ROBOT control data	Yes
UDP 1140	ROBOT-to-Dashboard status data	Yes
HTTP 80	Camera connected via switch on the ROBOT	Yes
HTTP 443	Camera connected via switch on the ROBOT	Yes
UDP/TCP 554	Real-Time Streaming Protocol for h.264 camera streaming	Yes
UDP/TCP 5800-5810	Team Use	Yes

Teams may use these ports as they wish if they do not employ them as outlined above (e.g. TCP 1180 can be used to pass data back and forth between the ROBOT and the Driver Station software if the Team chooses not to use the camera on USB). Note that ROBOT code cannot be deployed while connected to the FMS. Additional information about the FMS may be found in the [FMS Whitepaper](#).





4 MATCH Play

During each *FIRST*[®] STEAMWORKSSM MATCH, two ALLIANCES (an ALLIANCE is a cooperative of up to four (4) *FIRST*[®] Robotics Competition Teams) rush to best prepare their AIRSHIPS for a long distance race. Well prepared AIRSHIPS have as much steam pressure stored in the STEAM TANK and as many ROTORS on the AIRSHIP activated as possible.

- STEAM Pressure: ROBOTS collect FUEL and use the FUEL to stoke their BOILERS and make STEAM Pressure (as measured in kilopascals, kPa). Each ALLIANCE has one High Efficiency BOILER and one Low Efficiency BOILER. As FUEL is loaded in to BOILERS, pressure is built at rates defined in Table 4-1, and added to the ALLIANCE'S score.
- ROTORS: ROBOTS collect GEARS from their HUMAN PLAYER stationed on the opposite end of the FIELD. ROBOTS then deliver GEARS to PILOTS on their AIRSHIP, who then install them. GEARS installed properly complete the GEAR sets used to drive ROTORS on the AIRSHIP. ALLIANCES earn extra points for any ROTOR started during AUTO.

Bonus points are awarded for ROBOTS that signify that they're ready for takeoff by latching on to their AIRSHIP via the ROPES.

4.1 Periods

Each MATCH is divided in to two periods. The first period, called AUTO, is the first fifteen (15) seconds of a MATCH in which ROBOTS operate without any DRIVE TEAM control or input. During this period, ROBOTS attempt to deliver preloaded GAME PIECES (and PILOTS race to install delivered GEARS), retrieve additional GAME PIECES, and cross their BASE LINE before the start of the next period.

TELEOP is the second period in a MATCH and is two minutes and fifteen seconds (2:15) long. During this period, DRIVERS may operate ROBOTS remotely to retrieve and deliver GAME PIECES, defend against their opponents, and climb their ROPES to prepare for the impending departure of their AIRSHIP after the MATCH.

4.2 MATCH Setup

Each MATCH consists of two (2) minutes and thirty (30) seconds of game play, as well as pre- and post-MATCH time for setup and reset of the ARENA. During ARENA Reset, the ARENA is cleared of ROBOTS and OPERATOR CONSOLES from the MATCH that just ended. The ROBOTS and OPERATOR CONSOLES for the following MATCH must be placed in position and ready to operate before the start of the next MATCH. FIELD STAFF reset the ARENA elements during this time.

Each MATCH begins with GAME PIECES, elements used to score points, staged as shown in Figure 4-1. Staging details are as follows:

- FUEL
 - A. Ten (10) available for each TEAM to preload in their ROBOT (any not preloaded are staged in the bin referenced in the next bullet, B)
 - B. Twenty (20) in each LOADING LANE (in a bin staged between the LOADING STATION and the STARTING LINE)
 - C. One hundred (100) in each HOPPER (i.e. fifty (50) in each HOPPER container)

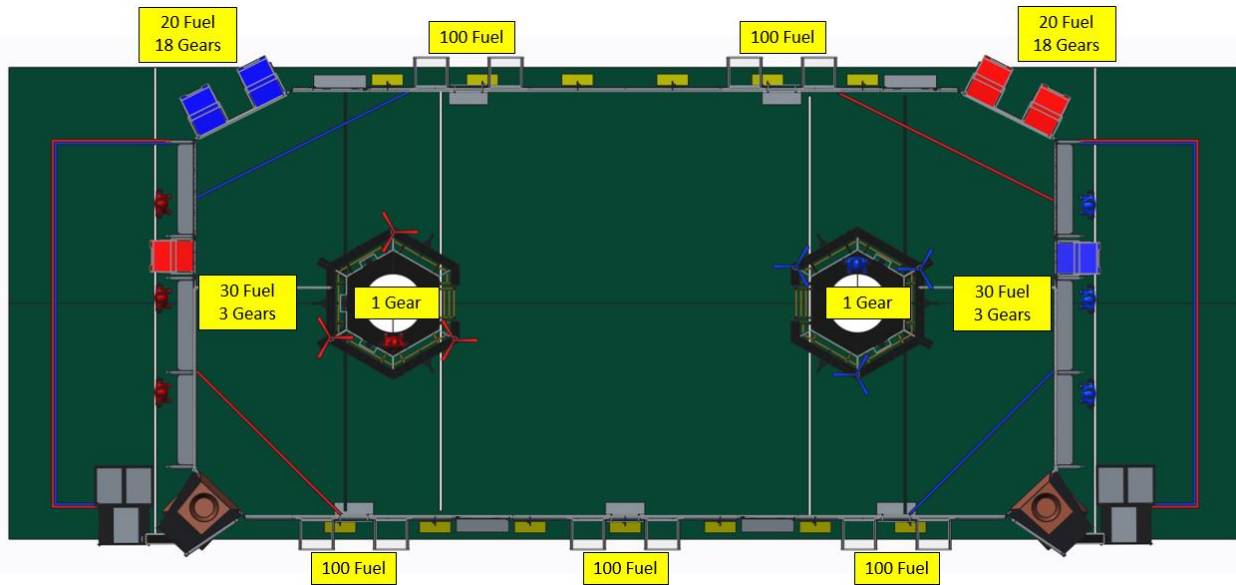




- GEARS

- D. One (1) available to each team to preload in their ROBOT (any not preloaded are staged with GEARS in E)
- E. Eighteen (18) in each LOADING LANE (staged on the carpet between the LOADING STATION and the STARTING LINE)
- F. One (1) in each AIRSHIP

Figure 4-1: GAME PIECE staging



When a DRIVE TEAM loads their ROBOT onto the FIELD for a MATCH they may elect to:

- A. pre-load one (1) GEAR in or on their ROBOT such that it is fully and only supported by the ROBOT. Any GEARS not preloaded in a ROBOT are transferred to their LOADING LANE.
and
- B. pre-load up to ten (10) FUEL in or on their ROBOT such that they are fully and only supported by the ROBOT. Any FUEL not preloaded in a ROBOT is transferred to a RETURN BIN in their LOADING LANE.

“Support”, in reference to pre-loaded GAME PIECES, is transitive through other GAME PIECES. For example, a FUEL is “fully supported by the ROBOT” if it is resting on top of a GEAR that is in turn on a ROBOT (and thus both GAME PIECES are “fully supported” by the ROBOT).

A DRIVE TEAM may elect to switch one of the ROPES on their AIRSHIP for their own ROPE that meets the criteria defined in 104 of [Section 9 Inspection & Eligibility Rules](#) and has a serialized Inspection tag. Once the DRIVE TEAM has installed their ROPE on the AIRSHIP, it is part of the FIELD, but any issues with it will not result in an ARENA FAULT.

If order placement of ROBOTS or ROPES matters to either or both ALLIANCES, the ALLIANCE must notify the Head REFEREE during setup for that MATCH. Upon notification, the Head REFEREE will require ALLIANCES alternate placement of all ROBOTS and then all ROPES, starting with the Red





ALLIANCE and in order of PLAYER STATION assigned (i.e. Red Station 1 ROBOT, Blue Station 1 ROBOT, Red Station 2 ROBOT, Blue Station 2 ROBOT...Red Station 1 ROPE, Blue Station 1 ROPE, Red Station 2 ROPE...).

4.3 Scoring

ALLIANCES are rewarded for accomplishing various actions including autonomous movement, pressure accumulation, ROTOR engagement, getting a ROBOT ready for takeoff, and winning and tying MATCHES. Rewards are granted either via MATCH points (which contribute to the ALLIANCE'S MATCH score) or Ranking Points (which increases the measure used to rank teams in the Qualification tournament). Such actions, their criteria for completion, and their point values are listed in Table 4-1. Scores are assessed and updated throughout the MATCH.

Fractions of kilopascals accumulate as an ALLIANCE stokes the BOILER with FUEL in the High and Low Efficiency GOALS. For example, during TELEOP, an ALLIANCE scores twelve (12) FUEL in the Low Efficiency GOAL and five (5) FUEL in the High Efficiency GOAL. As a result, the ALLIANCE has generated three (3) kPa of pressure ($= 12/9 + 5/3$).

MATCH points increment as whole unit kilopascals are achieved. For example, during TELEOP, an ALLIANCE scores fourteen (14) FUEL in the Low Efficiency GOAL and five (5) FUEL in the High Efficiency GOAL. As a result, they have generated $3\frac{2}{9}$ kPa of pressure ($= 14/9 + 5/3$), and their MATCH points increment by three (3) points. They do not receive a fourth MATCH point unless and until they score enough FUEL in the high and Low Efficiency GOAL to generate four (4) kPa of pressure.

Fractions of kilopascals generated in AUTO carry over and contribute to the TELEOP pressure. For example, if an ALLIANCE scores seventeen (17) FUEL in the Low Efficiency GOAL in AUTO, the ALLIANCE receives five (5) MATCH points and has generated $5\frac{2}{3}$ kPa of pressure. Once TELEOP begins, the ALLIANCE scores another three (3) FUEL in the Low Efficiency GOAL. Their pressure is now six (6) kPa and they're awarded a sixth MATCH point.





Table 4-1: FIRST STEAMWORKS rewards

Action	Criteria	MATCH Points		Ranking Points
		AUTO	TELEOP	
AUTO mobility	For each ROBOT that breaks the BASE LINE vertical plane with their BUMPER by T=0	5		
Pressure accumulation	For every three (3) FUEL counted in the Low Efficiency GOAL by T=0	1	-	
	For every one (1) FUEL counted in the High Efficiency GOAL by T=0	+ 1 kPa		-
	For every nine (9) FUEL counted in the Low Efficiency GOAL by T=0		1	
	For every three (3) FUEL counted in the High Efficiency GOAL by T=0	-	+ 1 kPa	
	If ALLIANCE meets or exceeds a threshold pressure of 40 kPa		20 (Playoffs only)	1 (Quals only)
ROTOR engagement	For each ROTOR turning by period's T=0, that's not previously been scored	60	40	-
	If all four (4) ROTORS turning by T=0		100 (Playoffs only)	1 (Quals only)
Ready for Takeoff	For each TOUCHPAD triggered by a ROBOT at T=0		50	-
Win	ALLIANCE's final score exceeds their opponents'			2 (Quals only)
Tie	ALLIANCE's final score equals their opponents'			1 (Quals only)

Although the STEAM TANK lights as described in [Section 3.6 STEAM TANK](#) have an upper limit to the amount of Pressure they can display, there is no limit on the Pressure an ALLIANCE can accumulate.

FUEL contributes to an ALLIANCE'S pressure and MATCH score only once it is counted, which occurs after it's loaded in a BOILER. The BOILER'S rate of processing FUEL is detailed in [Section 3.11.4 BOILER](#) and should be taken in to consideration when loading FUEL in the final seconds of AUTO and TELEOP. The BOILER counters shut off at T=0, and any uncounted FUEL (i.e. FUEL that has not passed by the sensors) does not contribute to pressure accumulation or MATCH points.

Like the reduction of prepopulated GEARS for Championships described in [Section 3.4.2 GEAR Sets](#), the threshold pressure may also increase for District Championships or FIRST® Championship.





4.4 Rule Violations

Upon a rule violation, one or more of the penalties listed in Table 4-2 will be assessed.

Table 4-2: Penalty Table

Action	Penalty
FOUL	5 points credited towards the opponent's total score.
TECH FOUL	25 points credited towards the opponent's total score.
YELLOW CARD	a warning issued by the Head REFEREE for egregious ROBOT or Team member behavior or rule violations. A subsequent YELLOW CARD within the same tournament phase will lead to a RED CARD.
RED CARD	a penalty assessed for egregious ROBOT or Team member behavior, or rule violations, which results in a Team being DISQUALIFIED for the MATCH.
DISABLED	ROBOT will be commanded to deactivate all outputs, rendering the ROBOT inoperable for the remainder of the MATCH.
DISQUALIFIED	the status of a Team, as determined by the Head REFEREE, in which their Team receives zero (0) MATCH points in a qualification MATCH or causes their ALLIANCE to receive zero (0) MATCH points in a Playoff MATCH

In addition to rule violations explicitly listed in this manual and witnessed by a REFEREE, the Head REFEREE may assign a YELLOW or RED CARD as a result of egregious ROBOT actions or Team member behavior at the event. Please see [Section 10.7 YELLOW and RED CARDS](#) for additional detail.

4.5 DRIVE TEAM

A DRIVE TEAM is a set of up to five (5) people from the same FIRST Robotics Competition Team responsible for Team performance during a MATCH. There are four (4) specific roles on a DRIVE TEAM which ALLIANCES can use to assist ROBOTS with race preparation.

Table 4-3: DRIVE TEAM roles

Role	Description	Max./ DRIVE TEAM	Criteria
COACH	responsible for acting as a guide or advisor	1	<ul style="list-style-type: none"> • Pre-college student or adult mentor • Must wear "Coach" button
DRIVER	responsible for operating and controlling the ROBOT	4	
HUMAN PLAYER	responsible for managing GAME PIECES	4	
PILOT	responsible for installing GEARS, starting ROTORS, and deploying ROPES	1	

There may be up to two (2) PILOTS per ALLIANCE per MATCH. During Qualification MATCHES, PILOTS may come from the DRIVE TEAMS assigned to Stations 1 and 2. A Team is permitted to cede their PILOT position to a PILOT from the DRIVE TEAM assigned to Station 3. During Playoff MATCHES, the ALLIANCE CAPTAIN has the authority on which two separate teams provide the ALLIANCE'S PILOTS.





PILOTS are strongly encouraged to make sure safety glasses fit properly, secure them with eyewear retainers, avoid loose fitting clothing and jewelry, and tie back long hair.

4.6 Logistics

Any GAME PIECES that leave the FIELD will not be returned to MATCH play. GAME PIECES that inadvertently bounce back in to the FIELD will be considered fair game.

Note that ROBOTS may not deliberately cause GAME PIECES to leave the FIELD (see G22).

GAME PIECES that roll, slide, or otherwise transfer from a LOADING LANE to an ALLIANCE STATION (or vice versa) are considered “owned” by the ALLIANCE in the space now occupied by the GAME PIECE.

There will not be an ARENA FAULT called for MATCHES that accidentally begin with an incorrect number of GAME PIECES, damaged GAME PIECES, or experience the failure of a Team provided ROPE.





5 Safety Rules

Safety is paramount at all times during any Tournament, and each rule below is intended to establish norms at each event that will mitigate injury risk to all participants.

Event staff have the final decision authority for all safety-related issues within a venue.

- S01. Safety glasses: required.** All event attendees must wear ANSI-approved, UL Listed, or CSA rated non-shaded safety glasses while in the ARENA. Lightly tinted lenses are permitted provided eyes are clearly visible to others, but reflective lenses are prohibited.

Violation: Attendee must immediately remedy or leave the ARENA.

- S02. Closed-toed shoes: required.** All event attendees must wear closed-toed shoes while in the ARENA.

Violation: Attendee must immediately remedy or leave the ARENA.

- S03. Dangerous ROBOTS: not allowed.** ROBOTS whose operation or design is dangerous or unsafe are not permitted.

Examples include, but are not limited to:

- A. Uncontrolled motion that cannot be stopped by the DRIVE TEAM
- B. ROBOT parts “flailing” outside of the FIELD
- C. ROBOTS dragging their battery
- D. ROBOTS that consistently extend beyond the FIELD

Violation: If before the MATCH, the offending ROBOT will not be allowed to participate in the MATCH. If during the MATCH, the offending ROBOT will be DISABLED.

- S04. Wait for the green lights.** DRIVE TEAMS may only enter the FIELD if the LED strings are green, unless explicitly instructed by a REFEREE or an FTA.

Violation: YELLOW CARD.

- S05. ROBOTS, stay on the FIELD during the MATCH.** ROBOTS and anything they control, e.g. a GEAR, may not contact anything outside the FIELD with the exception of brief incursions into the GOALS.

Please be conscious of REFEREES, and FIELD STAFF working around the ARENA who may be in close proximity to your ROBOT.

Violation: Offending ROBOT will be DISABLED.

- S06. Humans, stay off the FIELD during the MATCH.** DRIVE TEAMS (except for PILOTS, see S07) may not extend any body part into the FIELD during the MATCH.

Examples of egregious violations that are likely to escalate the Violation to a RED CARD include, but are not limited to, walking onto the FIELD during a MATCH or intentionally reaching into the FIELD and grabbing a ROBOT during a MATCH.

Violation: YELLOW CARD





- S07. Keep your hands “inside” the vehicle at all times.** During the MATCH, the PILOT may neither
- A. contact ROTORS,
 - B. contact DAVITS, nor
 - C. reach outside any PORT.

Violation: YELLOW CARD

- S08. Stay out of the chute.** DRIVE TEAMS may not contact the inside surfaces of the chute nor any part of a GAME PIECE that is within the volume of the chute. Momentary contact while feeding GAME PIECES into the chute is an exception to this rule.

Violation: FOUL.

- S09. Never step/jump over the GUARDRAIL.** DRIVE TEAMS may only enter or exit the FIELD through open gates.

Violation: YELLOW CARD.

- S10. Wireless operation: on FIELD and Practice Field only.** Wireless ROBOT control is only permitted on the FIELD or Practice FIELD. ROBOTS must be operated by tether when outside the FIELD or Practice FIELD.

Violation: Verbal warning. Repeated violations will be addressed by the Head REFEREE, the Lead ROBOT Inspector and/or Event Management.

- S11. If wireless on Practice Field, use FIRST's radio.** If operating wirelessly on the Practice FIELD, ROBOTS must use the provided Practice Field radio for communication.

Violation: Verbal warning. Repeated violations will be addressed by the Head REFEREE, the Lead ROBOT Inspector and/or Event Management.

- S12. Climb facing the ladder, but don't operate it.** PILOTS may only enter and exit the AIRSHIP under the following criteria:

- A. a member of the FIELD STAFF has released the ladder,
- B. one rung at a time, and
- C. facing your AIRSHIP.

Violation: Verbal warning. If jumped off AIRSHIP, YELLOW CARD. Repeated violations will be addressed by the Head REFEREE, the Lead ROBOT Inspector and/or Event Management.





6 Conduct Rules

- C01. Be a good person.** All Teams must be civil towards their own Team members, other Teams, competition personnel, FIELD STAFF, and event attendees while at a *FIRST*[®] Robotics Competition event.

Violation: Behavior will be discussed with Team or individual. Violations of this rule are likely to escalate to YELLOW or RED CARDS rapidly (i.e. the threshold for egregious or repeated violations is relatively low.)

Examples of egregious behavior include, but are not limited to, inappropriate behavior such as repeated use of offensive language or other uncivil conduct.

- C02. Asking other Teams to throw a MATCH – not cool.** A Team may not encourage an ALLIANCE, of which it is not a member, to play beneath its ability.

NOTE: This rule is not intended to prevent an ALLIANCE from planning and/or executing its own strategy in a specific MATCH in which all the Teams are members of the ALLIANCE.

Example #1: A MATCH is being played by Teams A, B, and C, in which Team C is encouraged by Team D to not deliver GEARS, resulting in Teams A, B, and C not earning a Ranking Point for the ROTOR achievement. Team D's motivation for this behavior is to prevent Team A from rising in the Tournament rankings and negatively affecting Team D's ranking.

Example #2: A MATCH is being played by Teams A, B, and C, in which Team A is assigned to participate as a SURROGATE. Team D encourages Team A to not participate in the MATCH so that Team D gains ranking position over Teams B and C.

FIRST[®] considers the action of a Team influencing another Team to throw a MATCH, to deliberately miss Ranking Points, etc. incompatible with *FIRST* values and not a strategy any team should employ.

Violation: Behavior will be discussed with Team or individual. Violations of this rule are likely to escalate rapidly to YELLOW or RED CARDS, and may lead to dismissal from the event (i.e. the threshold for egregious or repeated violations is relatively low.)

- C03. Letting someone coerce you in to throwing a MATCH – also not cool.** A Team, as the result of encouragement by a Team not on their ALLIANCE, may not play beneath its ability.

NOTE: This rule is not intended to prevent an ALLIANCE from planning and/ or executing its own strategy in a specific MATCH in which all the ALLIANCE members are participants.

Example #1: A MATCH is being played by Teams A, B, and C. Team D requests Team C to not deliver GEARS resulting in Teams A, B, and C not earning a Ranking Point for the ROTOR achievement. Team C accepts this request from Team D. Team D's motivation for this behavior is to prevent Team A from rising in the Tournament rankings negatively affecting Team D's ranking.





Example #2: A MATCH is being played by Teams A, B, and C, in which Team A is assigned to participate as a SURROGATE. Team A accepts Team D's request to not participate in the MATCH so that Team D gains ranking position over Teams B and C.

FIRST considers the action of a Team influencing another Team to throw a MATCH, to deliberately miss Ranking Points, etc. incompatible with *FIRST* values and not a strategy any team should employ.

Violation: Behavior will be discussed with Team or individual. Violations of this rule are likely to escalate rapidly to YELLOW or RED CARDS, and may lead to dismissal from the event (i.e. the threshold for egregious or repeated violations is relatively low.)

- C04. Compete with only one (1) ROBOT.** Each registered *FIRST* Robotics Competition team may enter only one (1) ROBOT (or 'Robot', which to a reasonably astute observer, is a ROBOT built to play *FIRST* STEAMWORKS) into the 2017 *FIRST* Robotics Competition.

"Entering" a ROBOT (or Robot) in to a *FIRST* Robotics Competition means bringing it to the event such that it's an aid to your Team (e.g. for spare parts, judging material, or for practice). Spare FABRICATED ITEMS may be brought to the event in a bag or part of a WITHHOLDING ALLOWANCE.

This rule does not prohibit teams from bringing in robots from other *FIRST* programs for the purposes of awards presentations or pit displays.

Violation: Verbal warning. Repeated violations will be addressed by the Head REFEREE, the Lead ROBOT Inspector and/or Event Management.

- C05. Don't set up wireless networks.** Teams may not set up their own 802.11a/b/g/n/ac (2.4GHz or 5GHz) wireless communication (e.g. access points or ad-hoc networks) in the venue.

A wireless hot spot created by a cellular device is considered an access point.

Violation: Verbal warning. Repeated violations will be addressed by the Head REFEREE, the Lead ROBOT Inspector and/or Event Management.

- C06. Don't try to hack networks.** No Team or Team member shall interfere or attempt to interfere with any other Team's or *FIRST* wireless communication. Except as expressly allowed for purposes of communicating with the Team's own ROBOT on the FIELD or a Practice FIELD, no Team or Team member shall connect or attempt to connect to any other Team's or *FIRST*'s wireless network.

Teams are encouraged to report suspected wireless security vulnerabilities to the *FIRST* Technical Advisor (FTA) if at the event or to *FIRST* via the [Wireless Security Feedback Form](#).

Violation: Behavior will be discussed with Team or individual. Violations of this rule are likely to escalate rapidly to YELLOW or RED CARDS, and may lead to dismissal from the event (i.e. the threshold for egregious or repeated violations is relatively low.) Legal action may also be pursued based on applicable law.

- C07. Show up to your MATCHES.** Each Team must send at least one (1) member of its DRIVE TEAM to the FIELD and participate in each of the Team's assigned Qualification and Playoff

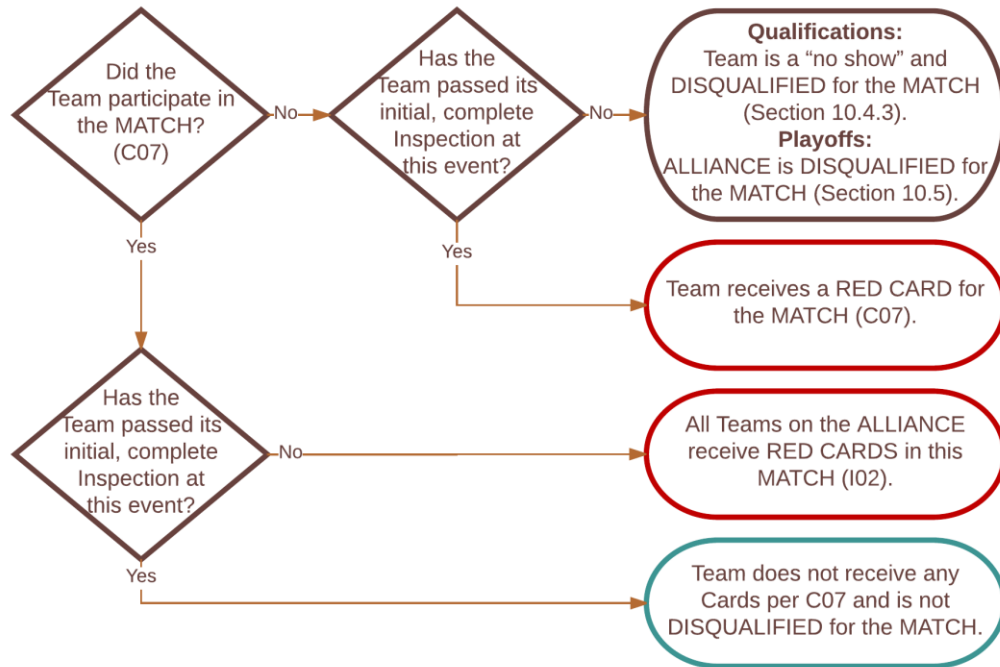




MATCHES. The Team should inform the Lead Queuer if the Team's ROBOT is not able to participate.

Violation: If ROBOT has passed an initial, complete Inspection, RED CARD. If ROBOT has not passed an initial, complete Inspection, DISQUALIFIED per I02.

Figure 6-1: Match participation flowchart



C08. Don't expect to gain by doing others harm. Strategies aimed solely at forcing the opposing ALLIANCE to violate a rule are not in the spirit of FIRST Robotics Competition and not allowed. Rule violations forced in this manner will not result in an assignment of a penalty to the targeted ALLIANCE.

Violation: FOUL. If egregious or repeated, YELLOW CARD.

C08 does not apply for strategies consistent with standard gameplay, e.g. contacting an opponent while in your RETRIEVAL ZONE to retrieve GAME PIECES.

C08 requires an intentional act with limited or no opportunity for the TEAM being acted on to avoid the penalty, e.g. pinning an opponent in your KEY such that they cannot help but violate G17.

C09. One student, one Head REFEREE. A Team may only send one (1) pre-college student from its DRIVE TEAM to address the Head REFEREE.

Please see [Section 10.6 REFEREE Interaction](#) for more information about process and expectations.

Violation: The Head REFEREE will not address additional, non-compliant Team members or peripheral conversations.



- C10. Even BANNERS have standards.** If brought to the ARENA, the Team BANNER must be constructed to the [Team Banner Specification](#) and installed such that
- A. its vertical support is in the BANNER holder in the PLAYER STATION to which the Team is assigned, as indicated on the Team sign and,
 - B. oriented with its horizontal support piece parallel to the ALLIANCE WALL.

Violation: The MATCH will not start until the situation is corrected or the Team banner is removed from the ARENA.

- C11. Keep your hands off your BANNER.** During a MATCH, the Team BANNER may not be touched by any member of the ALLIANCE

Violation: FOUL, an exception is given for a Team BANNER which is damaged and/or dangling in front of a DRIVE TEAM.

- C12. Plug in to/be in your PLAYER STATION.** The OPERATOR CONSOLE must be used in the PLAYER STATION to which the Team is assigned, as indicated on the Team sign.

Violation: The MATCH will not start until the situation is corrected. If during a MATCH, YELLOW CARD.

One intent of C12 is to prevent unsafe situations where long tethers to OPERATOR CONSOLE devices increase tripping hazards as the operator moves about the ALLIANCE STATION. In the interest of avoiding nuisance penalties associated with an operator stepping outside of a prescribed area, we prefer to offer a general guideline as to what it means to use the OPERATOR CONSOLE in the ALLIANCE STATION. Provided the operator is within close proximity of their PLAYER STATION, there will be no repercussions. However, if an operator is located more than approximately $\frac{1}{2}$ PLAYER STATION width away from their own PLAYER STATION, that would be considered a violation of C12.

- C13. No work outside your pit.** Throughout the event, from load-in to load-out, Teams may only produce FABRICATED ITEMS in their pit area, other Teams' pit areas with permission from that Team, or as permitted at provided machine shops.

Violation: Verbal warning. Repeated or egregious violations will be addressed by the Head REFEREE, the Lead ROBOT Inspector and/or Event Management.





7 Game Rules

7.1 Before the MATCH

G01. Know your ROBOT setup. When placed on the FIELD for a MATCH, each ROBOT must be:

- A. in compliance with all ROBOT rules, i.e. has passed Inspection (for exceptions regarding Practice MATCHES, see [Section 9 Inspection & Eligibility Rules](#)),
- B. the only item left on the FIELD by the DRIVE TEAM,
- C. confined to its STARTING CONFIGURATION,
- D. set on the carpet,
- E. in contact with its ALLIANCE WALL diamond plate, and
- F. supporting not more than 10 FUEL and 1 GEAR (as described in [Section 4.2 MATCH Setup](#)).

Violation: If fix is a quick remedy, the MATCH won't start until all requirements are met. If it is not a quick remedy the offending ROBOT will be DISABLED and, at the discretion of the Head REFEREE, must be re-inspected.

If a ROBOT is BYPASSED prior to the start of the MATCH, the DRIVE TEAM may not remove the ROBOT from the FIELD without permission from the Head REFEREE or the *FIRST*[®] Technical Advisor (FTA).

G02. Be prompt/safe when coming to and going from the FIELD. DRIVE TEAMS may not cause significant or repeated delays to the start of a MATCH and/or to the FIELD reset at the conclusion of the MATCH.

Violation: If prior to the MATCH, the offending DRIVE TEAM'S ROBOT will be DISABLED. If after the MATCH, YELLOW CARD.

DRIVE TEAMS are expected to stage their ROBOTS for a MATCH, and remove it from the FIELD afterwards, safely and swiftly. Examples include, but are not limited to:

- E. late arrival to the FIELD
- F. failing to exit the FIELD once the LED strings have turned off (indicating MATCH ready)
- G. installing BUMPERs, charging pneumatic systems, or any other ROBOT maintenance, once on the FIELD
- H. use of alignment devices that are external to the ROBOT
- I. failing to remove OPERATING CONSOLES from the PLAYER STATIONS in a timely manner
- J. convoluted installation and removal of TEAM supplied ROPE





- G03. Know your DRIVE TEAM positions.** Prior to the start of the MATCH, DRIVE TEAMS must be positioned as follows:
- A. DRIVERS and COACHES must be in their ALLIANCE STATION and behind the STARTING LINE
 - B. At least one (1) PILOT must be on their AIRSHIP (please refer to [Section 4.5 DRIVE TEAM](#) for details regarding which DRIVE TEAMS provide the PILOT(S))
 - C. HUMAN PLAYERS (that are not PILOTS) must be behind the STARTING LINE and in their ALLIANCE STATION or LOADING LANE

Violation: MATCH will not start until the situation is corrected.

7.2 ROBOT Restrictions

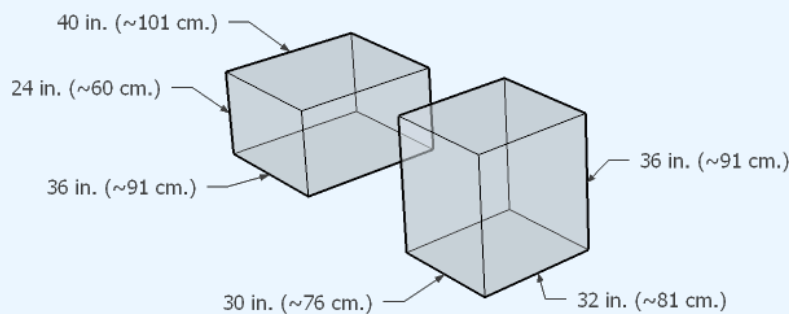
- G04. Don't overextend yourself.** A ROBOT may not exceed the volume for which it passed Inspection during the MATCH.

Violation: FOUL. If strategic, (e.g. expansion results in the TOUCHPAD being triggered), RED CARD.

The two (2) distinct ROBOT volumes permitted are defined in R03 and included below for reference:

- A. 36 in. by 40 in. by 24 in. tall (~91 cm by 101 cm by 60 cm tall)
- B. 30 in. by 32 in. by 36 in. tall (~76 cm by 81 cm by 91 cm tall)

Figure 7-1: Permitted ROBOT volumes



These measurements are intended to be made as if the ROBOT is resting on a flat floor, not relative to the height of the ROBOT from the FIELD carpet.

As a result, a ROBOT that fits in one of the permitted volumes and has climbed a ROPE such that its highest point is 4 ft. (~122 cm) from the floor has not violated G04 as it is not considered 4 ft. (~122 cm) tall.

Additionally, a ROBOT that is angled as it climbs a rope (such that a diagonal of length that exceeds the volume's height restriction becomes vertical), does not violate G04, assuming that if it's virtually transposed to a flat floor without changing configuration, it's within its permitted volume.





G05. Keep your BUMPERS together. ROBOTS must be in compliance with BUMPER Rules throughout the MATCH.

Violation: FOUL. DISABLED if any BUMPER segment becomes completely detached or the Team number or ALLIANCE color becomes indeterminate.

G06. ROBOTS must be removed from the FIELD by hand (i.e. no enabling, power, etc.). ROBOTS will not be re-enabled after the conclusion of the MATCH, nor will Teams be permitted to tether to the ROBOT except in special circumstances (e.g. during TIMEOUTS, after Opening Ceremonies, before an immediate MATCH replay, etc.) and with the express permission from the FTA or a REFEREE.

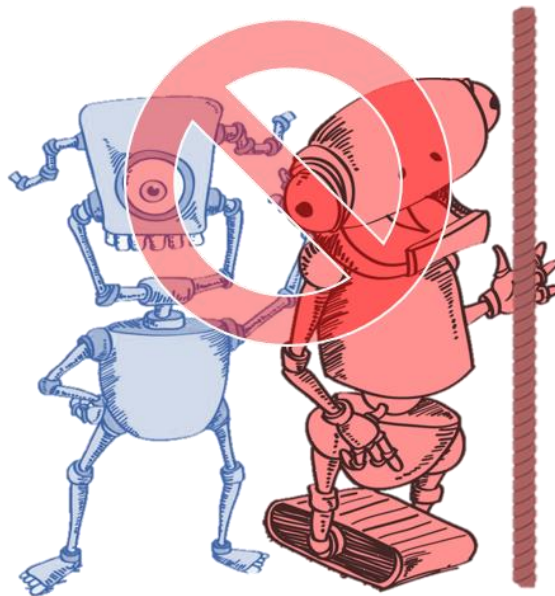
Violation: YELLOW CARD.

Tethering includes any wired or wireless connection used to electrically energize and/or control elements on the ROBOT. The safety of Teams and Volunteers in close proximity to ROBOTS and ARENA elements on the FIELD is of the utmost importance, therefore ROBOTS or ROBOT COMPONENTS may not be energized or powered in any way on the FIELD once the MATCH has concluded.

7.3 ROBOT to ROBOT Interaction

G07. Opponent touching their ROPE: don't touch them. ROBOTS may not contact an opposing ROBOT, regardless of who initiates the contact, if the opposing ROBOT is in contact with one of its own ALLIANCE'S ROPES.

Figure 7-2: Don't touch opponents touching their ROPES.



Violation: The opposing ROBOT is considered to have triggered an un-triggered TOUCHPAD at the end of the MATCH.

Teams are encouraged to consider rule C08 when developing their strategies, such as attempting to draw violations of this rule.



- G08. Don't tear others down to lift yourself up.** Strategies aimed at the destruction or inhibition of ROBOTS via attachment, damage, tipping, entanglements, or deliberately putting a GEAR on an opponent's ROBOT are not allowed.

Violation: FOUL and YELLOW CARD. If harm or incapacitation occurs as a result of the strategy, RED CARD

- G09. Stay out of other ROBOTS.** Initiating deliberate or damaging contact with an opponent ROBOT on or inside the vertical extension of its FRAME PERIMETER is not allowed.

Violation: FOUL and YELLOW CARD.

- G10. Don't collude with your partners to shut down major parts of game play.** Two or more ROBOTS may not isolate or close off any major facet of MATCH play, e.g. block all three opponent LIFTS, shut down all access to GAME PIECES, quarantine all opponents to a small area of the FIELD, etc.

Violation: YELLOW CARD for the ALLIANCE.

A single ROBOT blocking access to a particular area of the FIELD is not a violation of G10.

- G11. There's a 5-count on pins.** ROBOTS may not pin an opponent's ROBOT for more than five (5) seconds. A ROBOT will be considered pinned until the ROBOTS have separated by at least six (6) feet. The pinning ROBOT(s) must then wait for at least three (3) seconds before attempting to pin the same ROBOT again. Pinning is transitory through other objects. If the pinned ROBOT chases the pinning ROBOT upon retreat, the pinning ROBOT will not be penalized, and the pin will be considered complete.

Violation: FOUL. For every five (5) seconds in which the situation is not corrected, FOUL. If extended and egregious, RED CARD.

There is no *FIRST*[®] Robotics Competition specific definition of pin, so a general definition applies; "to prevent or stop something from moving." As a result, contact is not required for pinning to occur. For example, a ROBOT parked right behind an opponent that is between dividers could be considered pinning because the dividers and the parked ROBOT prevent the opponent from moving.

Generally, pins that exceed fifteen (15) seconds are considered extended and egregious, regardless of a pinning ROBOT's mobility, however circumstances vary and the assessment is open to REFEREE discretion.

- G12. If an opponent's down, back off.** Fallen (i.e. tipped over) ROBOTS attempting to right themselves (either by themselves or with assistance from a partner ROBOT) have one ten (10) second grace period in which they may not be contacted by an opponent ROBOT. This protection lasts for either ten (10) seconds or until the protected ROBOT has completed the righting operation, whichever comes first.

Violation: FOUL. If intentional, YELLOW CARD.

- G13. Don't mess with a ROBOT in their RETRIEVAL ZONE.** A ROBOT with any part inside its opponent's RETRIEVAL ZONE may not contact an opposing ROBOT, regardless of who initiates the contact.

Violation: TECH FOUL.





TEAMS should take note that they are putting themselves at great risk for FOULS if they choose to enter their opponent's RETRIEVAL ZONE.

G14. Don't climb on each other. ROBOTS may neither fully nor partially support the weight of other ROBOTS strategically or repeatedly.

Violation: RED CARD.

7.4 FIELD Interaction

G15. Be careful about what you grab on to. DRIVE TEAMS, ROBOTS, and OPERATOR CONSOLES are prohibited from the following actions with regards to interaction with ARENA elements.

Items A and B exclude DRIVE TEAM interaction with FIELD elements in their areas.

Item C excludes use of the PLAYER STATION hook-and-loop tape, plugging in to the provided power outlet, and plugging the provided Ethernet cable in to the OPERATOR CONSOLE.

Items A-E exclude GAME PIECES.

Items A-G exclude ROPES installed on an ALLIANCE'S AIRSHIP.

- A. Grabbing
- B. Grasping
- C. Attaching to (including the use of hook-and-loop tape against the FIELD carpet)
- D. Grappling
- E. Hanging
- F. Deforming
- G. Becoming entangled
- H. Damaging

Violation: If prior to MATCH, and situation can be corrected quickly, it must be remedied before the MATCH will start. If during a MATCH, FOUL. If during a MATCH and extended or repeated, YELLOW CARD. If offense is via a ROBOT and the Head REFEREE determines that further damage is likely to occur, offending ROBOT will be DISABLED. Corrective action (such as eliminating sharp edges, removing the damaging MECHANISM, and/or re-Inspection) may be required before the ROBOT will be allowed to compete in subsequent MATCHES.

GAME PIECES are expected to undergo a reasonable amount of wear and tear as they are handled by ROBOTS, such as scratching or marking. Gouging, tearing off pieces, or routinely marking GAME PIECES are violations of this rule. Humans causing GAME PIECE wear and tear, e.g. flattening FUEL, are subject to a CARD per [Section 10.7 YELLOW and RED CARDS](#).

G16. Keep it together. ROBOTS may not intentionally detach or leave parts on the FIELD.

Violation: RED CARD

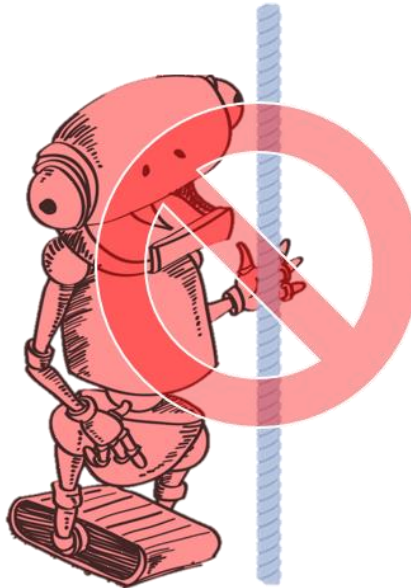
This rule is not intended to penalize ROBOTS that encounter accidental breakage (e.g. a failed MECHANISM that falls off), as those actions are not intentional.





- G17. Opponent's KEY: a no parking zone.** A ROBOT may not be in their opponent's KEY for more than five (5) seconds (if the ROBOT is breaking the plane of the line with BUMPERS, it is considered in the KEY).
Violation: FOUL. For every five (5) seconds in which the situation is not corrected, FOUL.
- G18. One ROBOT per ROPE.** No more than one (1) ROBOT may be fully supported by a ROPE.
Violation: RED CARD.
- G19. Only climb on deployed ROPES.** A ROBOT may only pull on a ROPE if/once the ROPE is supported only by the DAVIT, the carpet, the ROBOT, or any combination thereof.
Violation: RED CARD.
- G20. Let 'em climb: don't touch their ROPES.** During the final thirty (30) seconds of a MATCH, ROBOTS may not contact an opposing ALLIANCE'S ROPE.

Figure 7-3: Don't touch opponents' ROPES in the final thirty (30) seconds of the MATCH.



Violation: FOUL. If an opposing ROBOT contacts the offending ROBOT or the ROPE, the opposing ROBOT is considered to have triggered an un-triggered TOUCHPAD at the end of the MATCH.

7.5 GAME PIECE Interaction

- G21. GAME PIECES: use as directed.** ROBOTS may not deliberately use GAME PIECES, e.g. GEARS, in an attempt to ease or amplify the challenge associated with other FIELD elements, e.g. BOILERS, HOPPERS, or ROPES.
Violation: YELLOW CARD.
- G22. Keep GAME PIECES in bounds.** ROBOTS may not intentionally eject GAME PIECES from the FIELD other than through BOILERS.
Violation: FOUL. Repeated or extended violations of this rule are likely to escalate rapidly to YELLOW or RED CARDS.





- G23. Shoot FUEL from your own LAUNCHPAD.** A ROBOT may only LAUNCH FUEL while in their LAUNCHPAD (i.e. at least breaking the plane of the line with BUMPERS).

For the purposes of *FIRST*[®] STEAMWORKSSM, LAUNCHING is defined as shooting in the air, kicking or rolling across the floor with an active mechanism, or throwing in a forceful way.

A ROBOT that has bumped FUEL has not LAUNCHED it.

Violation: FOUL. Repeated or extended violations of this rule are likely to escalate rapidly to YELLOW or RED CARDS.

- G24. Don't throw GEARS at all.** A ROBOT may not LAUNCH a GEAR.

Violation: YELLOW CARD.

- G25. AIRSHIPS run on steam, not FUEL.** ROBOTS may not intentionally put FUEL in an AIRSHIP.

Violation: YELLOW CARD.

- G26. If you're going to deliver GEARS, you have to use a LIFT.** Any GEAR transferred to a PILOT during the MATCH must be done so via a LIFT.

Violation: TECH FOUL and a YELLOW CARD.

- G27. One-GEAR limit.** ROBOTS may not control more than one GEAR at a time.

Violation: FOUL. If strategic, TECH FOUL and YELLOW CARD.

Moving or positioning a GEAR to gain advantage is considered "control." Examples include, but are not limited to:

- A. "carrying" (holding a GEAR inside a ROBOT)
- B. "herding" (intentionally pushing a GEAR to a desired location or direction)
- C. "trapping" (holding a GEAR against a FIELD element in an attempt to shield or guard it)

Examples of interaction with GEARS that are not "control" include, but are not limited to:

- A. "bulldozing" (inadvertent contact with GEARS while in the path of the ROBOT moving about the FIELD)
- B. "deflecting" (being hit by a GEAR that bounces into or off of a ROBOT).

If a GEAR becomes lodged in or on a ROBOT, it will be considered controlled by the ROBOT. It is important to design your ROBOT so that it is impossible to inadvertently or unintentionally control more than the allowed maximum.

- G28. Don't use air to direct/redirect FUEL.** ROBOTS may not use forced air to affect the movement of FUEL that is outside the volume of the ROBOT.

Violation: RED CARD.





7.6 AUTO Period Rules

- A01. Behind the lines.** During AUTO, DRIVE TEAM members in ALLIANCE STATIONS and LOADING LANES may not contact anything in front of the STARTING LINES, unless for personal or equipment safety.

Violation: FOUL.

Pointing, gesturing or otherwise extending across the STARTING LINE such that contact is not made with carpet or other ARENA elements is not a violation of this rule.

One example of an exception for equipment safety is if an OPERATOR CONSOLE starts to slide from the PLAYER STATION shelf. In that circumstance, DRIVE TEAM members may step forward to catch it and return it. However, if an OPERATOR CONSOLE has already hit the ground, the damage has already been done, and touching it before TELEOP starts is not an exception for equipment safety.

- A02. During AUTO, let the ROBOT do its thing.** During AUTO, DRIVE TEAMS may not directly or indirectly interact with ROBOTS or OPERATOR CONSOLES unless for personal safety, OPERATOR CONSOLE safety, or pressing an E-Stop for ROBOT safety.

Violation: FOUL and YELLOW CARD.

- A03. Disconnect or set down controllers.** During AUTO, any control devices worn or held by the DRIVERS and/or HUMAN PLAYERS must be disconnected from the OPERATOR CONSOLE.

Violation: FOUL.

- A04. Stay out of your opponent's LAUNCHPAD.** During AUTO, no part of a ROBOT'S BUMPERS may enter their opponent's LAUNCHPAD.

Violation: FOUL. If contact is made with an opponent ROBOT in their LAUNCHPAD (either direct contact or transitive contact through another object), TECH FOUL.

- A05. PILOTS: don't take the "free" GEAR yet.** During AUTO, PILOTS may not remove the reserve GEAR from the slot in which it begins the MATCH.

Violation: TECH FOUL.

7.7 Human Action Rules

- H01. COACHES and other Teams: hands off the controls.** A ROBOT shall be operated solely by the DRIVERS and/or HUMAN PLAYERS of that Team.

Violation: Offending ROBOT will be DISABLED.

Exceptions may be made before a MATCH for major conflicts, e.g. religious holidays, major testing, transportation issues, etc.

- H02. Wireless devices not allowed.** During a MATCH, DRIVE TEAMS may not use electronic devices which have the capability of receiving communications from persons outside of the ARENA (e.g. cell phones or wearable technology).

Violation: YELLOW CARD.

- H03. Leave FIELD scoring elements alone.** Teams may not interfere with any automated scoring hardware.





Violation: RED CARD for the ALLIANCE.

Examples of violations of this rule include, but are not limited to, tampering with the sensors, putting anything but a GEAR in the GEAR slot for ROTOR 1, blocking FUEL from exiting the BOILER, or attempting to feed FUEL backwards through a BOILER.

H04. By invitation only. Only DRIVE TEAMS for the current MATCH are allowed in their respective ALLIANCE STATIONS, LOADING LANES, and AIRSHIPS.

Violation: MATCH will not start until the situation is corrected.

H05. Identify yourself. DRIVE TEAMS must wear proper identification while in the ARENA. Proper identification consists of:

- A. All DRIVE TEAM members wearing their designated buttons above the waist in a clearly visible location at all times while in the ARENA.
 - i. The COACH wearing the "Coach" labeled drive team button
 - ii. The DRIVERS and HUMAN PLAYERS each wearing a DRIVE TEAM button
- B. During a Playoff MATCH, the ALLIANCE CAPTAIN clearly displaying the designated ALLIANCE CAPTAIN identifier (e.g. hat or armband).

Violation: MATCH will not start until the situation is corrected. Those not displaying identification must leave the ARENA.

H06. COACHES, no GAME PIECES. COACHES may not touch GEARS or FUEL unless for safety purposes.

Violation: FOUL.

H07. No wandering. DRIVE TEAM members may not contact anything outside the zone in which they started the MATCH (e.g. the AIRSHIP, LOADING LANE, or ALLIANCE STATION) during the MATCH. Exceptions will be granted for inadvertent, momentary, and inconsequential infractions and in cases concerning safety.

Violation: FOUL. If strategic, RED CARD.

H08. GAME PIECES through LOADING STATIONS only. ALLIANCES may only deliberately cause GAME PIECES to leave an ALLIANCE STATION or LOADING LANE

- A. during TELEOP,
- B. by a HUMAN PLAYER or DRIVER, and
- C. through a LOADING STATION slot.

Violation: FOUL per GAME PIECE. If strategic, RED CARD.

H09. PILOTS, keep the GEARS. PILOTS may not throw GEARS from the AIRSHIP.

Violation: RED CARD.

Accidentally dropping a GEAR is not a violation of H09.

H10. GEARS stay installed. Once a ROTOR is started, the PILOT may not remove any GEARS used to start it.

Violation: RED CARD.

H11. Don't release ROPES early. PILOTS may not deploy ROPES (i.e. cause a ROPE to extend below the deck of the AIRSHIP) until there are 30 or fewer seconds left in the MATCH.





Violation: FOUL. If deployed with more than 35 seconds left in the match, TECH FOUL.

The ARENA will sound an alert when thirty (30) seconds remain in TELEOP.

H12. You can't bring/use anything you want. The only equipment that may be brought to the ARENA and used by DRIVE TEAMS during a MATCH is listed below. Regardless if equipment fits criteria below, it may not be employed in a way that breaks any other rules, blocks visibility for FIELD STAFF or audience members, or jams or interferes with the remote sensing capabilities of another Team, including vision systems, acoustic range finders, sonars, infrared proximity detectors, etc. (e.g. including imagery that, to a reasonably astute observer, mimics the Vision Guides).

- A. the OPERATOR CONSOLE,
- B. BANNERS and devices, if needed, to assist placement in the BANNER Holder,
- C. non-powered signaling devices,
- D. reasonable decorative items,
- E. special clothing and/or equipment required due to a disability
- F. devices used solely for the purpose of planning or tracking strategy provided they meet all of the following conditions:
 - i. do not connect or attach to the OPERATOR CONSOLE
 - ii. do not connect or attach to the FIELD or ARENA
 - iii. do not connect or attach to another ALLIANCE member
 - iv. do not communicate with anything or anyone outside of the ARENA.
 - v. do not include any form of enabled wireless electronic communication (e.g. radios, walkie-talkies, cell phones, Bluetooth communications, Wi-Fi, etc.)
 - vi. do not in any way affect the outcome of a MATCH, other than by allowing PLAYERS to plan or track strategy for the purposes of communication of that strategy to other ALLIANCE members.
- G. non-powered Personal Protective Equipment (examples include, but aren't limited to, gloves, eye protection, and hearing protection)

Violation: MATCH will not start until situation remedied. If discovered or used inappropriately during a MATCH, TECH FOUL.

H13. FUEL overboard? Only out the PORT. In a circumstance where FUEL gets in an AIRSHIP, the only way a PILOT may remove it is by dropping it through the PORT.

Violation: FOUL per FUEL.

H14. You have to use the CRANK. PILOTS may only start ROTORS 2, 3, and 4 by turning the CRANK installed in the first GEAR in the set.

Violation: YELLOW CARD.

H15. Seriously, GEARS stay installed. A pre-populated GEAR may not be removed from its AXLE.

Violation: RED CARD.





8 ROBOT Rules

This section of the 2017 *FIRST*® Robotics Competition Game Manual presents legislation relevant to the construction of a 2017 *FIRST* Robotics Competition ROBOT. ROBOTS must pass Inspection at each *FIRST* Robotics Competition event to confirm compliance before being allowed to compete, per [Section 9 Eligibility & Inspection](#).

8.1 Overview

The rules listed below explicitly address legal parts and materials and how those parts and materials may be used on a 2017 ROBOT. There are many reasons for the structure of the rules, including safety, reliability, parity, creation of a reasonable design challenge, adherence to professional standards, impact on the competition, and compatibility with the Kit of Parts (KOP), which is the collection of items listed on any Kickoff Kit Checklists, distributed via *FIRST*® Choice, or obtained via a Product Donation Voucher (PDV).

Another intent of these rules is to have all energy sources and active actuation systems on the ROBOT (e.g. batteries, compressors, motors, servos, cylinders, and their controllers) drawn from a well-defined set of options. This is to ensure that all Teams have access to the same actuation resources and that the Inspectors are able to accurately assess the legality of a given part.

ROBOTS are made up of COMPONENTS and MECHANISMS. A COMPONENT is any part in its most basic configuration, which cannot be disassembled without damaging or destroying the part or altering its fundamental function. A MECHANISM is a COTS or custom assembly of COMPONENTS that provide specific functionality on the ROBOT. A MECHANISM can be disassembled (and then reassembled) into individual COMPONENTS without damage to the parts.

Many rules in this section reference Commercial-Off-The-Shelf (COTS) items. A COTS item must be a standard (i.e. not custom order) part commonly available from a VENDOR for all Teams for purchase. To be a COTS item, the COMPONENT or MECHANISM must be in an unaltered, unmodified state. Items that are no longer commercially available but are functionally equivalent to the original condition as delivered from the VENDOR are considered COTS and may be used.

- Example 1: A Team orders two (2) ROBOT grippers from RoboHands Corp. and receives both items. They put one in their storeroom and plan to use it later. Into the other, they drill “lightening holes” to reduce weight. The first gripper is still classified as a COTS item, but the second gripper is now a FABRICATED ITEM, as it has been modified.
- Example 2: A Team obtains openly available blueprints of a drive module commonly available from Wheels-R-Us Inc. and has local machine shop “We-Make-It, Inc.” manufacture a copy of the part for them. The produced part is NOT a COTS item, because it is not commonly carried as part of the standard stock of We-Make-It, Inc.
- Example 3: A Team obtains openly available design drawings from a professional publication during the pre-season, and uses them to fabricate a gearbox for their ROBOT during the build period following Kickoff. The design drawings are considered a COTS item, and may be used as “raw material” to fabricate the gearbox. The finished gearbox itself would be a FABRICATED ITEM, and not a COTS item.





- Example 4: A COTS part that has non-functional label markings added would still be considered a COTS part, but a COTS part that has device-specific mounting holes added is a FABRICATED ITEM.
- Example 5: A team has a COTS single-board processor version 1.0, which can no longer be purchased. Only the COTS single-board processor version 2.0 may be purchased. If the COTS single-board processor version 1.0 is functionally equivalent to its original condition, it may be used.
- Example 6: A team has a COTS gearbox which has been discontinued. If the COTS gearbox is functionally equivalent to its original condition, it may be used.

A **VENDOR** is a legitimate business source for COTS items that satisfies all of the following criteria:

- A.** has a Federal Tax Identification number. In cases where the **VENDOR** is outside of the United States, they must possess an equivalent form of registration or license with the government of their home nation that establishes and validates their status as a legitimate business licensed to operate within that country.
- B.** is not a “wholly owned subsidiary” of a *FIRST* Robotics Competition Team or collection of Teams. While there may be some individuals affiliated with both a Team and the **VENDOR**, the business and activities of the Team and **VENDOR** must be completely separable.
- C.** must be able to ship any general (i.e., non-*FIRST* unique) product within five business days of receiving a valid purchase request. It is recognized that certain unusual circumstances (such as 1,000 *FIRST* Teams all ordering the same part at once from the same **VENDOR**) may cause atypical delays in shipping due to backorders for even the largest **VENDOR**s. Such delays due to higher-than-normal order rates are excused.
- D.** should maintain sufficient stock or production capability to fill Teams’ orders within a reasonable period during the season (less than 1 week). (Note that this criterion may not apply to custom-built items from a source that is both a **VENDOR** and a fabricator. For example, a **VENDOR** may sell flexible belting that the Team wishes to procure to use as treads on their drive system. The **VENDOR** cuts the belting to a custom length from standard shelf stock that is typically available, welds it into a loop to make a tread, and ships it to a Team. The fabrication of the tread takes the **VENDOR** two weeks. This would be considered a FABRICATED ITEM, and the two-week ship time is acceptable.) Alternately, the Team may decide to fabricate the treads themselves. To satisfy this criterion, the **VENDOR** would just have to ship a length of belting from shelf stock (i.e. a COTS item) to the Team within five business days and leave the welding of the cuts to the Team.)
- E.** makes their products available to all *FIRST* Robotics Competition Teams. **VENDOR** must not limit supply or make a product available to just a limited number of *FIRST* Robotics Competition Teams.

The intent of this definition is to be as inclusive as possible to permit access to all legitimate sources, while preventing ad hoc organizations from providing special-purpose products to a limited subset of Teams in an attempt to circumvent the cost accounting rules.





FIRST desires to permit Teams to have the broadest choice of legitimate sources possible, and to obtain COTS items from the sources that provide them with the best prices and level of service available. Teams also need to protect against long delays in availability of parts that will impact their ability to complete their ROBOT. The build season is brief, so the VENDOR must be able to get their product, particularly *FIRST* unique items, to a Team in a timely manner.

Ideally, chosen VENDORS should have national distributors (e.g. Home Depot, Lowes, MSC, Radio Shack, McMaster-Carr, etc.). Remember, *FIRST* Robotics Competition events are not always near home – when parts fail, local access to replacement materials is often critical.

A FABRICATED ITEM is any COMPONENT or MECHANISM that has been altered, built, cast, constructed, concocted, created, cut, heat treated, machined, manufactured, modified, painted, produced, surface coated, or conjured partially or completely into the final form in which it will be used on the ROBOT.

Note that it is possible for an item (typically raw materials) to be neither COTS nor a FABRICATED ITEM. For example, a 20 ft. length of aluminum which has been cut into 5 ft. (~152 cm) pieces by the Team for storage or transport is neither COTS (it's not in the state received from the VENDOR), nor a FABRICATED ITEM (the cuts were not made to advance the part towards its final form on the ROBOT).

Teams may be asked to provide documentation proving legality of non-2017 KOP items during Inspection where a Rule specifies limits for a legal part (e.g. pneumatic items, current limits, COTS electronics, etc.).

Some of these rules make use of English unit requirements for parts. If your team has a question about a metric-equivalent part's legality, please e-mail your question to frcparts@firstinspires.org for an official ruling. To seek approval for alternate devices for inclusion in future *FIRST* Robotic Competition seasons, please contact frcparts@firstinspires.org with item specifications.

Teams should acknowledge the support provided by the corporate Sponsors and Mentors with an appropriate display of their school and Sponsors names and/or logos (or the name of the supporting youth organization, if appropriate).

FIRST Robotics Competition can be a full-contact competition and may include rigorous game play. While the rules aim to limit severe damage to ROBOTS, Teams should design their ROBOTS to be robust.

8.2 General ROBOT Design

- R01.** The ROBOT (excluding BUMPERS) must have a FRAME PERIMETER, contained within the BUMPER ZONE, that is comprised of fixed, non-articulated structural elements of the ROBOT. Minor protrusions no greater than $\frac{1}{4}$ in. (~6.3 mm) such as bolt heads, fastener ends, weld beads, and rivets are not considered part of the FRAME PERIMETER.

To determine the FRAME PERIMETER, wrap a piece of string around the ROBOT (excluding BUMPERS) at the BUMPER ZONE described in R23 and pull it taut. The string describes this polygon.

Example: A ROBOT's chassis is shaped like the letter 'V', with a large gap between chassis elements on the front of the ROBOT. When wrapping a taut string around this chassis, the string extends across the gap and the resulting FRAME PERIMETER is a triangle with three sides.





Note: to permit a simplified definition of the FRAME PERIMETER and encourage a tight, robust connection between the BUMPERS and the FRAME PERIMETER, minor protrusions such as bolt heads, fastener ends, rivets, etc. are excluded from the determination of the FRAME PERIMETER.

- R02.** In the STARTING CONFIGURATION (the physical configuration in which a ROBOT starts a MATCH), no part of the ROBOT shall extend outside the vertical projection of the FRAME PERIMETER, with the exception of its BUMPERS and minor protrusions such as bolt heads, fastener ends, rivets, etc.

If a ROBOT is designed as intended and each side is pushed up against a vertical wall (in STARTING CONFIGURATION and with BUMPERS removed), only the FRAME PERIMETER (or minor protrusions) will be in contact with the wall.

- R03.** Maximum ROBOT size, including BUMPERS and all extensions, must be constrained to one of two volumes:
- A. 36 in. by 40 in. by 24 in. tall (~91 cm by 101 cm by 60 cm tall).
 - B. 30 in. by 32 in. by 36 in. tall (~76 cm by 81 cm by 91 cm tall).

The ROBOT must remain constrained to the maximum inspected volume at all times during the MATCH (i.e. A ROBOT may not switch between volume A and volume B without being re-inspected).

Expect to have to demonstrate a ROBOT'S ability to constrain itself per above during Inspection. Constraints may be implemented with either hardware or software.

Be sure to consider the size of the ROBOT on its cart to make sure it will fit through doors. Also consider the size of the ROBOT to ensure that it will fit into a shipping crate, bag, vehicle, etc.

- R04.** The ROBOT weight must not exceed 120 lbs. When determining weight, the basic ROBOT structure and all elements of all additional MECHANISMS that might be used in different configurations of the ROBOT shall be weighed together.

For the purposes of determining compliance with the weight limitations, the following items are excluded:

- A. ROBOT BUMPERS
- B. ROBOT battery and its associated half of the Anderson cable quick connect/disconnect pair (including no more than 12 in. (~30 cm) of cable per leg, the associated cable lugs, connecting bolts, and insulation)

8.3 ROBOT Safety & Damage Prevention

- R05.** Traction devices must not have surface features such as metal, sandpaper, hard plastic studs, cleats, hook-loop fasteners or similar attachments that could damage the ARENA. Traction devices include all parts of the ROBOT that are designed to transmit any propulsive and/or braking forces between the ROBOT and FIELD carpet.
- R06.** Protrusions from the ROBOT and exposed surfaces on the ROBOT shall not pose hazards to the ARENA elements (including the GAME PIECES) or people.





If the ROBOT includes protrusions that form the “leading edge” of the ROBOT as it drives and have a surface area of less than 1 in.² (~6 cm²), it will invite detailed Inspection. For example, forklifts, lifting arms, or grapplers may be carefully Inspected for these hazards.

- R07.** ROBOT parts shall not be made from hazardous materials, be unsafe, cause an unsafe condition, or interfere with the operation of other ROBOTS.

Examples of items that will violate R07 include (but are not limited to):

- A.** Shields, curtains, or any other devices or materials designed or used to obstruct or limit the vision of any DRIVERS and/or COACHES and/or interfere with their ability to safely control their ROBOT
- B.** Speakers, sirens, air horns, or other audio devices that generate sound at a level sufficient to be a distraction
- C.** Any devices or decorations specifically intended to jam or interfere with the remote sensing capabilities of another ROBOT, including vision systems, acoustic range finders, sonars, infrared proximity detectors, etc. (e.g. including imagery on your ROBOT that, to a reasonably astute observer, mimics the retro-reflective features of vision targets described in [Section 3.13 Vision Targets](#))
- D.** Exposed lasers other than Class I.
- E.** Flammable gasses
- F.** Any device intended to produce flames or pyrotechnics
- G.** Hydraulic fluids or hydraulic items
- H.** Switches or contacts containing liquid mercury
- I.** Circuitry used to create voltages in excess of 24 Volts
- J.** Any ballast not secured sufficiently, including loose ballast e.g. sand, ball bearings, etc., such that it may become loose during a MATCH.
- K.** Exposed, untreated hazardous materials (e.g. lead weights) used on the ROBOT. These materials may be permitted if painted, encapsulated or otherwise sealed to prevent contact. These materials may not be machined in any way at an event.
- L.** Tire sealant
- M.** High intensity light sources used on the ROBOT (e.g. super bright LED sources marketed as ‘military grade’ or ‘self-defense’) may only be illuminated for a brief time while targeting and may need to be shrouded to prevent any exposure to participants. Complaints about the use of such light sources will be followed by re-inspection and possible disablement of the device.

Teams should provide MSD Sheets for any materials they use that might be considered questionable during ROBOT Inspection.

- R08.** ROBOTS must allow removal of GAME PIECES from the ROBOT and the ROBOT from FIELD elements while DISABLED and powered off.

ROBOTS will not be re-enabled after the MATCH, so Teams must be sure that GAME PIECES and ROBOTS can be quickly, simply, and safely removed. Note that a Team provided ROPE may be removed from





the FIELD and is no longer considered a FIELD element once removed from the DAVIT.

- R09. Lubricants may be used only to reduce friction within the ROBOT. Lubricants must not contaminate the ARENA or other ROBOTS.

8.4 Budget Constraints & Fabrication Schedule

- R10. The total cost of all items on the ROBOT shall not exceed \$4000 USD. All costs are to be determined as explained in [Section 8.4 Budget Constraints & Fabrication Schedule](#). Exceptions are as follows:

- A. individual COTS items that are less than \$5 USD each and
- B. KOP items

Teams should be prepared to disclose to Inspectors the cost of any non-KOP item and the total cost of the ROBOT.

Per I07, Teams must be prepared to display a Cost Accounting Worksheet (CAW) to Inspectors during Inspection. The CAW may be displayed in either printed or electronic form.

If the item is a KOP item, it does not need to be on the CAW.

Individual COMPONENTS or MECHANISMS, not excluded in R10, that are retrieved from previous ROBOTS and used on 2017 ROBOTS must have their undepreciated cost included in the 2017 CAW and applied to the overall cost assessment.

- R11. No individual, non-KOP item shall have a value that exceeds \$400 USD. The total cost of COMPONENTS purchased in bulk may exceed \$400 USD as long as the cost of an individual COMPONENT does not exceed \$400 USD.

If a COTS item is part of a modular system that can be assembled in several possible configurations, then each individual module must fit within the price constraints defined in R11.

If the modules are designed to assemble into a single configuration, and the assembly is functional in only that configuration, then the total cost of the complete assembly including all modules must fit within the price constraints defined in R11.

In summary, if a VENDOR sells a system or a kit, a team must use the entire system/kit Fair Market Value and not the value of its COMPONENT pieces.

Example 1: VENDOR A sells a gearbox that can be used with a number of different gear sets, and can mate with two different motors they sell. A team purchases the gearbox, a gear set, and a motor (which are not offered together as an assembly or kit), then assembles them together. Each part is treated separately for the purpose of CAW costing, since the purchased pieces can each be used in various configurations.

Example 2: VENDOR B sells a robotic arm assembly that the team wants to use. However, it costs \$700 USD, so they cannot use it. The VENDOR sells the “hand”, “wrist”, and “arm” as separate assemblies, for



\$200 USD each. A team wishes to purchase the three items separately, then reassemble them. This would not be legal, as they are really buying and using the entire assembly, which has a Fair Market Value of \$700 USD.

Example 3: VENDOR C sells a set of wheels or wheel modules that are often used in groups of four. The wheels or modules can be used in other quantities or configurations. A team purchases four and uses them in the most common configuration. Each part is treated separately for the purpose of CAW costing, since the purchased pieces can be used in various configurations.

- R12.** The CAW cost of each non-KOP item must be calculated based on the unit fair market value for the material and/or labor, except for labor provided by Team members (including sponsor employees who are members of the team), members of other Teams, event provided Machine Shops and shipping.

Example 1: A Team orders a custom bracket made by a company to the Team's specification. The company's material cost and normally charged labor rate apply.

Example 2: A Team receives a donated sensor. The company would normally sell this item for \$52 USD, which is therefore its fair market value.

Example 3: Special price discounts from National Instruments and other *FIRST* Suppliers are being offered to Teams. The discounted purchase price of items from these sources may be used in the additional parts accounting calculations.

Example 4: A Team purchases steel bar stock for \$10 USD and has it machined by a local machine shop. The machine shop is not considered a team Sponsor, but donates two (2) hours of expended labor anyway. The Team must include the estimated normal cost of the labor as if it were paid to the machine shop, and add it to the \$10 USD.

Example 5: A Team purchases steel bar stock for \$10 USD and has it machined by a local machine shop that is a recognized Sponsor of the Team. If the machinists are considered members of the Team, their labor costs do not apply. The total applicable cost for the part would be \$10 USD.

It is in the best interests of the Teams and *FIRST* to form relationships with as many organizations as possible. Teams are encouraged to be expansive in recruiting and including organizations in their team, as that exposes more people and organizations to *FIRST*. Recognizing supporting companies as Sponsors of, and members in, the Team is encouraged, even if the involvement of the Sponsor is solely through the donation of fabrication labor.

Example 6: A Team purchases steel bar stock for \$10 USD and has it machined by another Team. The total applicable cost for the part would be \$10 USD.

Example 7: A Team purchases a 4 ft. by 4 ft. (~122 cm by 122 cm) sheet of aluminum, but only uses a piece 10 in. by 10 in. (~24 cm by 25 cm) on





their ROBOT. The Team identifies a source that sells aluminum sheet in 1 by 1 ft. pieces. The Team may cost their part on the basis of a 1 by 1 ft. piece, even though they cut the piece from a larger bulk purchase. They do not have to account for the entire 4 by 4 ft. bulk purchase item.

- R13.** Physical ROBOT elements created before Kickoff are not permitted. Exceptions are:
- A.** OPERATOR CONSOLE,
 - B.** BUMPERS (a protective assembly designed to attach to the exterior of the ROBOT and constructed as specified in [Section 8.5 Bumper Rules](#)),
 - C.** battery assemblies per R04-B,
 - D.** FABRICATED ITEMS consisting of one COTS electrical device (e.g. a motor or motor controller), connectors, and any materials used to secure and insulate those connectors

Please note that this means that FABRICATED ITEMS from ROBOTS entered in previous *FIRST* competitions may not be used on ROBOTS in the 2017 *FIRST*® Robotics Competition (other than those allowed per R13-C and R13-D). Before the formal start of the Build Season, Teams are encouraged to think as much as they please about their ROBOTS. They may develop prototypes, create proof-of-concept models, and conduct design exercises. Teams may gather all the raw stock materials and COTS COMPONENTS they want.

Example 1: A Team designs and builds a two-speed shifting transmission during the fall as a training exercise. After Kickoff, they utilize all the design principles they learned in the fall to design their ROBOT. To optimize the transmission design for their ROBOT, they improve the transmission gear ratios and reduce the size, and build two new transmissions, and place them on the ROBOT. All parts of this process are permitted activities.

Example 2: A Team re-uses a 2017-legal motor from a previous ROBOT which has had connectors added to the wires. This is permitted, per exception D, because the motor is a COTS electrical COMPONENT.

- R14.** Software and mechanical/electrical designs created before Kickoff are only permitted if the source files (complete information sufficient to produce the design) are available publicly prior to Kickoff.

Example 1: A Team realizes that the transmission designed and built in the fall perfectly fits their need for a transmission to drive the ROBOT arm. They build an exact copy of the transmission from the original design plans, and bolt it to the ROBOT. This would be prohibited, as the transmission – although made during the competition season – was built from detailed designs developed prior to Kickoff.

Example 2: A Team developed an omni-directional drive system for the 2011 competition. Over the summer of 2011 they refined and improved the control software (written in C++) to add more precision and capabilities. They decided to use a similar system for the 2017 competition. They copied large sections of unmodified code over into the control software of the new ROBOT (also written in C++). This would be a violation of the schedule constraint, and would not be allowed.





Example 3: The same Team decides to use LabVIEW as their software environment for 2017. Following Kickoff, they use the previously-developed C++ code as a reference for the algorithms and calculations required to implement their omni-directional control solution. Because they developed new LabVIEW code as they ported over their algorithms, this would be permitted.

Example 4: A different Team develops a similar solution during the fall, and plans to use the developed software on their competition ROBOT. After completing the software, they post it in a generally accessible public forum and make the code available to all Teams. Because they have made their software publicly available before Kickoff, they can use it on their ROBOT.

Example 5: A Team develops a transmission during the fall. After completing the project, they publish the CAD files on a generally accessible public forum and make them available to all Teams. Because they have made the design publicly available before Kickoff, they can use the design to create an identical transmission, fabricated after Kickoff, for use on their 2017 ROBOT.

- R15.** All ROBOT elements (including items intended for use during the competition in alternative configurations of the ROBOT), with the exception of the WITHHOLDING ALLOWANCE per R21, BUMPERS, and COTS items, must be bagged and sealed, by 04:59 UTC on Stop Build Day, Wednesday, February 22, 2017.

To bag your ROBOT:

- Locate the “Bag and Tag” kit from your Kickoff Kit which contains two plastic bags large enough to contain your ROBOT and at least ten tags with individual serial numbers.
- Set the bag on the floor, leaving room for the ROBOT in the center.
- Place the ROBOT in the center of the bag and pull the bag up around the ROBOT. Be careful not to catch the bag on the corners or sharp edges.
- Tightly seal the bag with your next numbered tag.
- Complete the ROBOT Lock-up Form to verify the date and time that the bag was sealed. The ROBOT Lock-up Form must be signed by an adult, 18 years old or older, who is not a student on the team. This form must be brought with you to the event.

- R16.** For convenience, Teams may disassemble their ROBOT and use two (2) bags to “Bag and Tag” the pieces. However, no more than two (2) bags may be used and each bag must have its own numbered tag and entry on the ROBOT Lock-up Form.

When transporting their ROBOT, Teams may use any transportation method they wish (at their own risk and expense), as long as the ROBOT remains sealed in the bag.

- R17.** If you are attending another event, such as the *FIRST* Championship or another Regional or District event, you must re-seal your ROBOT in the bag with a new tag and enter the new tag number on the ROBOT Lock-up Form prior to leaving the event.





- R18.** Teams must stay “hands-off” their bagged ROBOT elements during the following time periods:
- A.** between Stop Build Day and their first event,
 - B.** during the period(s) between their events, and
 - C.** outside of Pit hours while attending events.

Modifying parts at night offsite (e.g. pits have closed and you bring a MECHANISM back to the hotel to fix it) is a violation of R18-C.

Additional time is allowed as follows:

- D.** After Kickoff, there are no restrictions on when software may be developed.
- E.** On days a team is not attending an event, they may continue development of any items permitted per R21, including items listed as exempt from R21, but must do so without interfacing with the ROBOT.
- F.** ROBOTS may be unbagged and operated briefly after “Stop Build Day” for brief display purposes only provided the following requirements are met:
 - i.** The ROBOT Lock-up Form must be used to track the unbagging and rebagging of the ROBOT during this period. In the “Explanation” column of the form, enter “Robot Display”.
 - ii.** No activity that could be considered “work on” or “practice with” the ROBOT is allowed.
 - iii.** Brief displays of robot functions, driving for example, are allowed, but not to the extent that they could be considered practice

The intent of this option is to allow Teams to briefly show their ROBOT to their community, sponsors, or potential sponsors after “Stop Build Day”. The intent is not to allow ‘exhibition matches’, or other similar activities, as this would be considered practice.

Unbagging a ROBOT and putting it on display for many hours (i.e., more than four (4)) at a time is not considered a “brief” display.

A good way to avoid turning a ROBOT display period in to a practice session is to have non-DRIVE TEAM members operate the ROBOT, and only for as short a time as necessary to show the ROBOT’S capabilities.

If you have any questions about the ROBOT Display option, please email frcparts@firstinspires.org.

- G.** Teams attending 2-day events may access their ROBOTS using the ROBOT Access Period.

Teams attending 2-day events will not have as much time to work on their ROBOTS at events as Teams attending traditional 3-day Regional events. Due to this, teams are granted an additional “Robot Access Period” to un-bag their ROBOT between the “Stop Build Day” and their 2-day district events. 2-day events for the 2017 season include District Qualifier events for the following areas:

- *FIRST* Chesapeake District (DC, MD, VA)
- *FIRST* in Michigan District (MI)





- *FIRST* Ontario District (ON)
- Indiana *FIRST* District (IN)
- Israel District (IS)
- Mid-Atlantic Robotics District (DE, NJ, Eastern PA)
- New England *FIRST* District (CT, MA, ME, NH, RI, VT)
- *FIRST* North Carolina District (NC)
- Pacific Northwest (AK, OR, WA)
- Peachtree District (GA)

R19. Teams permitted to use the ROBOT Access Period per R18-G may only unlock their ROBOT for a total of six (6) hours during the 7-day period preceding any 2-day event in which their Team will be competing with their ROBOT.

The six hours may be broken up in any way the team wishes, with the exception that no single access period may be shorter than two (2) hours.

The ROBOT must be locked up between sessions which must be documented on the ROBOT Lock-up Form.

R20. If the ROBOT is accessed before the event, the unbagging must be noted on the ROBOT Lock-up form and the ROBOT must be rebagged. The ROBOT must remain in the bag until:

- A.** Your ROBOT Lock-up Form has been checked and approved by an Inspector and
- B.** The pits have officially been opened for ROBOT work.

R21. At an Event, Teams may have access to a WITHHOLDING ALLOWANCE. The WITHHOLDING ALLOWANCE is a static set of FABRICATED ITEMS that shall not exceed 30 lbs. (~13 kg.), brought to an event (or ROBOT Access Period) in addition to the bagged items, to be used to repair and/or upgrade their ROBOT. With permission from another Team, Teams may also have access to FABRICATED ITEMS that are part of that other Team's WITHHOLDING ALLOWANCE to repair and/or upgrade their ROBOT. The WITHHOLDING ALLOWANCE may only be brought into the Venue when the Team initially loads in at the Event. Items made at an Event do not count towards this weight limit.

Teams should be prepared to show their WITHHOLDING ALLOWANCE items, and potentially have them weighed, during load-in.

This means teams may not store FABRICATED ITEMS outside the pits to be brought to the event at a later time. This set may be changed between events (i.e. a Team may leave a different set of items out of the bag and/or fabricate new items to bring to their next event) provided the total weight of FABRICATED ITEMS brought to the next event does not exceed thirty (30) lbs. (~13 kg.).

There is no restriction on the quantity of COTS items or items which do not meet the definitions of COTS or FABRICATED ITEMS (e.g. raw materials) that may be accessed by a Team at an Event.

For Teams attending 2-Day Events, these FABRICATED ITEMS may be used during the ROBOT Access Period and/or brought to the Event, but the total weight may not exceed 30 lbs. (~13 kg.) FABRICATED ITEMS constructed during the ROBOT Access Period and bagged with the ROBOT are exempt from this limit.





Example 1: A team creates 10 lbs (~4 kg.) of FABRICATED ITEMS after Stop Build Day. During their first ROBOT Access Period before their first event, they install these items on the ROBOT and bag them with the ROBOT. The team may bring up to 20 lbs. (~9 kg.) of FABRICATED ITEMS (which may be items removed from the ROBOT before bagging at the end of the ROBOT Access Period) with them to the event.

Example 2: A team creates 30 lbs (~13 kg.) of FABRICATED ITEMS after Stop Build Day. During their first ROBOT Access Period before their first event, they install these items on the ROBOT and bag them with the ROBOT. The team may not bring any FABRICATED ITEMS (including any initially bagged on Stop Build Day and removed during the ROBOT Access Period) with them to the event.

Items exempt from this limit are:

- A. the OPERATOR CONSOLE,
- B. any ROBOT battery assemblies (as described in R04-B).
- C. BUMPERS

8.5 BUMPER Rules

A BUMPER is a required assembly which attaches to the ROBOT frame. BUMPERS are important because they protect ROBOTS from damaging/being damaged by other ROBOTS and FIELD elements. Criteria used in writing these rules included the following:

- A. Minimize variety of BUMPERS so teams can expect consistency
- B. Minimize the amount of design challenge in creating BUMPERS
- C. Minimize cost of BUMPER materials
- D. Maximize use of relatively ubiquitous materials

R22. ROBOTS are required to use BUMPERS to protect all outside corners of the FRAME PERIMETER. For adequate protection, at least 6 in. (~16 cm) of BUMPER must be placed on each side of each outside corner (see Figure 8-1). If a FRAME PERIMETER side is shorter than 6 in. (~16 cm), that entire side must be protected by BUMPER (see Figure 8-2). A round or circular FRAME PERIMETER, or segment of the FRAME PERIMETER, is considered to have an infinite number of corners, therefore the entire frame or frame segment must be completely protected by BUMPER(S).

The dimension defined in R22 is measured along the FRAME PERIMETER. The portion of the BUMPER that extends beyond the corner of the FRAME PERIMETER is not included in the 6 in. (~16 cm) requirement. See Figure 8-1 below.





Figure 8-1: BUMPER corner examples

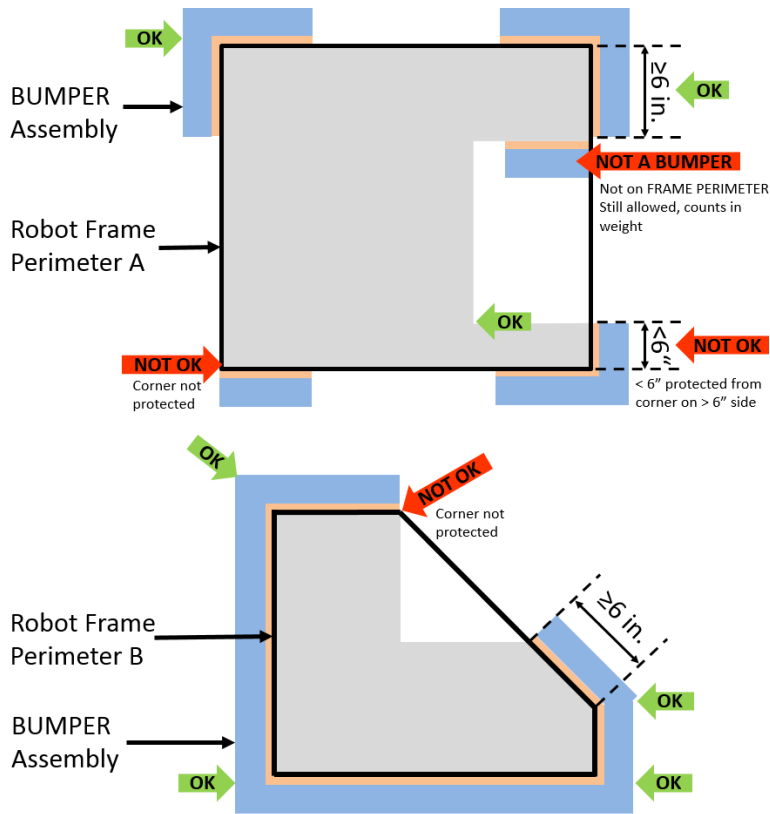
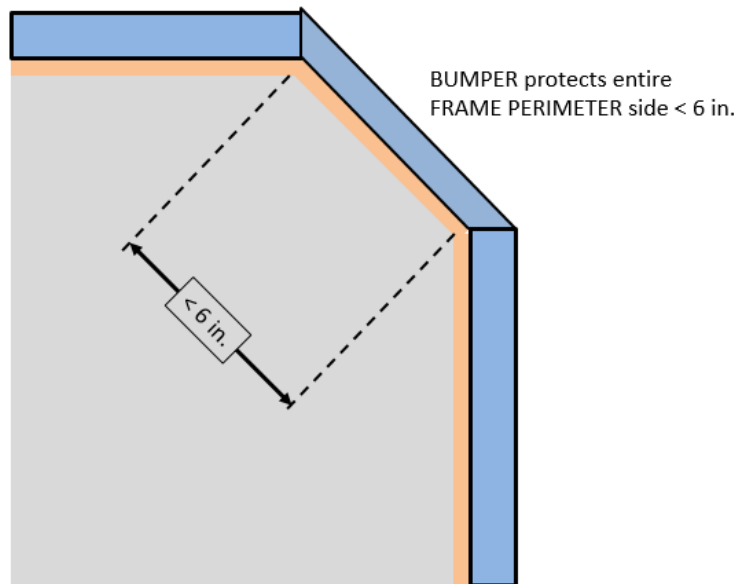


Figure 8-2: BUMPER around full side/corner.





- R23.** BUMPERS must be located entirely within the BUMPER ZONE, which is the volume contained between the floor and a virtual horizontal plane 7 in. (~17 cm) above the floor in reference to the ROBOT standing normally on a flat floor. BUMPERS do not have to be parallel to the floor.

This measurement is intended to be made as if the ROBOT is resting on a flat floor (without changing the ROBOT configuration), not relative to the height of the ROBOT from the FIELD carpet. Examples include:

Example 1: A ROBOT that is at an angle while navigating a ROPE has its BUMPERS outside the BUMPER ZONE. If this ROBOT were virtually transposed onto a flat floor, and its BUMPERS are in the BUMPER ZONE, it meets the requirements of R23.

Example 2: A ROBOT deploys a MECHANISM which LIFTS the BUMPERS outside the BUMPER ZONE (when virtually transposed onto a flat floor). This violates R23.

- R24.** BUMPERS must not be articulated (relative to the FRAME PERIMETER).
- R25.** BUMPERS (the entire BUMPER, not just the cover) must be designed for quick and easy installation and removal to facilitate inspection and weighing.

As a guideline, BUMPERS should be able to be installed or removed by two (2) people in fewer than five (5) minutes.

- R26.** Each ROBOT must be able to display Red or Blue BUMPERS to MATCH their ALLIANCE color, as assigned in the MATCH schedule distributed at the event (as described in [Section 10.4.1 Schedule](#)). BUMPER Markings visible when installed on the ROBOT, other than the following, are prohibited:

- A. those required per R27,
- B. hook-and-loop fastener backed by the hard parts of the BUMPER, and
- C. solid white *FIRST* logos between 4¾ in. (~13 cm) and 5¼ in. wide (~13 cm) (i.e. comparable to those distributed in the 2017 Kickoff Kit).

- R27.** Team numbers must be displayed and positioned on the BUMPERS such that an observer walking around the perimeter of the ROBOT can unambiguously tell the Team's number from any point of view and meet the following additional criteria:

- A. consist of numerals at least 4 in. (~11 cm) high, at least ½ in. (~12.7 mm) in stroke width, and be either white in color or outlined in white
- B. must not wrap around sharp corners (less than 160 degrees) of the FRAME PERIMETER
- C. may not substitute logos or icons for numerals

There is no prohibition against splitting Team numbers onto different sections of BUMPER. The intent is that the Team's number is clearly visible and unambiguous so that Judges, REFEREES, Announcers, and other Teams can easily identify competing ROBOTS.

- R28.** Each set of BUMPERS (including any fasteners and/or structures that attach them to the ROBOT) must weigh no more than 20 lbs (~9 kg).

If a multi-part attachment system is utilized (e.g. interlocking brackets on the ROBOT and the BUMPER), then the elements permanently attached to the ROBOT will be considered part of the ROBOT, and the elements





attached to the BUMPERS will be considered part of the BUMPER. Each element must satisfy all applicable rules for the relevant system.

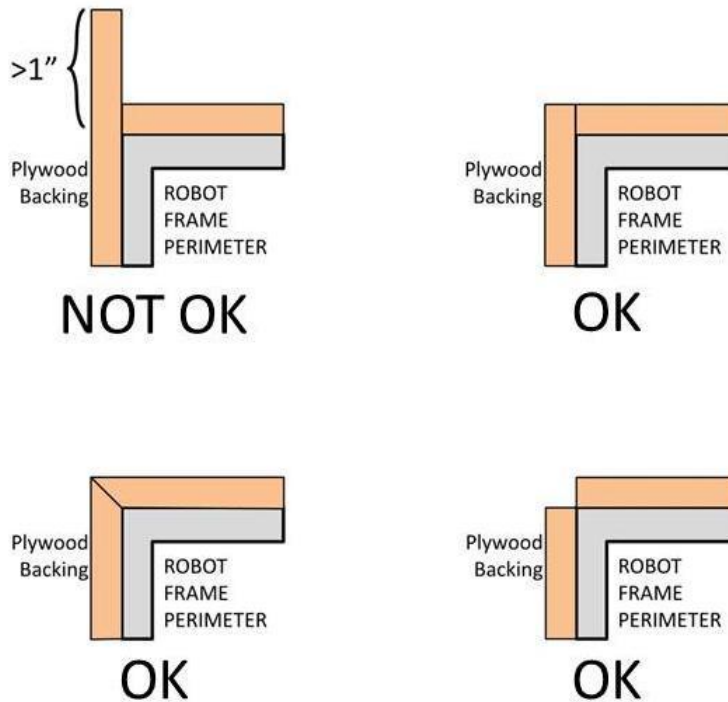
R29. BUMPERS must be constructed as follows (see Figure 8-5):

- A. be backed by $\frac{3}{4}$ in. (nominal) thick (~19mm) by 5 in. \pm $\frac{1}{2}$ in. (~127 mm \pm 12.7 mm) tall plywood or solid, robust wood. Small clearance pockets and/or access holes in the plywood backing are permitted, as long as they do not significantly affect the structural integrity of the BUMPER.

Particle board or chipboard is not likely to survive the rigors of *FIRST* Robotics Competition gameplay and thus not compliant with R29-A.

- B. hard BUMPER parts allowed per R29-A, R29-E, R29-F, and R29-G must not extend more than 1 in. (~25 mm) beyond the FRAME PERIMETER with the exception of minor protrusions such as bolt heads, fastener ends, rivets, etc. (Figure 8-3 and Figure 8-5).

Figure 8-3: Hard Parts of BUMPER Corners



- C. use a stacked pair of approximately 2½ in. (nominal) round, petal, or hex “pool noodles” (solid or hollow) as the BUMPER cushion material (see Figure 8-5). All pool noodles used in a BUMPER set (e.g. Red set of BUMPERS) may not be deformed and must be the same diameter, cross-section, and density (e.g. all round hollow or all hex solid). Cushion material may extend up to 2½ in. (~63 mm) beyond the end of the plywood (see Figure 8-6). To assist in applying the fabric covering, soft fasteners may be used to attach the pool noodles to the wood backing, so long as the cross section in Figure 8-5 is not significantly altered (e.g. tape compressing the pool noodles).

All pool noodles used on a ROBOT must be the same in order to maintain the desired interaction between ROBOTS in the cases of





BUMPER-to-BUMPER contact. BUMPERS containing pool noodles of vastly different construction may cause a “ramp” effect when interacting with other BUMPERS.

Noodle compression as a result of smoothing BUMPER fabric is not considered deformed. Any compression beyond that, e.g. for the purposes of flattening the noodle, is deformation and a violation of R29-C.

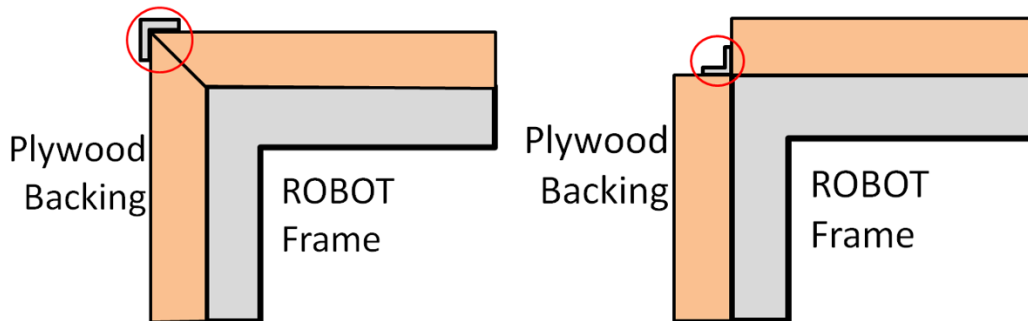
- D. be covered with a rugged, smooth cloth. (multiple layers of cloth and seams are permitted if needed to accommodate R26, provided the cross section in Figure 8-5 is not significantly altered).

Silk and bedding are not considered rugged materials, however 1000D Cordura is. Tape (e.g. gaffer’s tape) matching the BUMPER color is allowed to patch small holes on a temporary basis.

The cloth must completely enclose all exterior surfaces of the wood and pool noodle material when the BUMPER is installed on the ROBOT. The fabric covering the BUMPERS must be solid in color.

- E. optionally use aluminum angle, as shown in Figure 8-5 or other fasteners (e.g. staples, screws, etc.) to clamp cloth.
- F. Optionally use aluminum brackets (i.e. angle or sheet metal) to attach BUMPER segments to each other (see Figure 8-4).

Figure 8-4: Hard Parts of BUMPER Corners

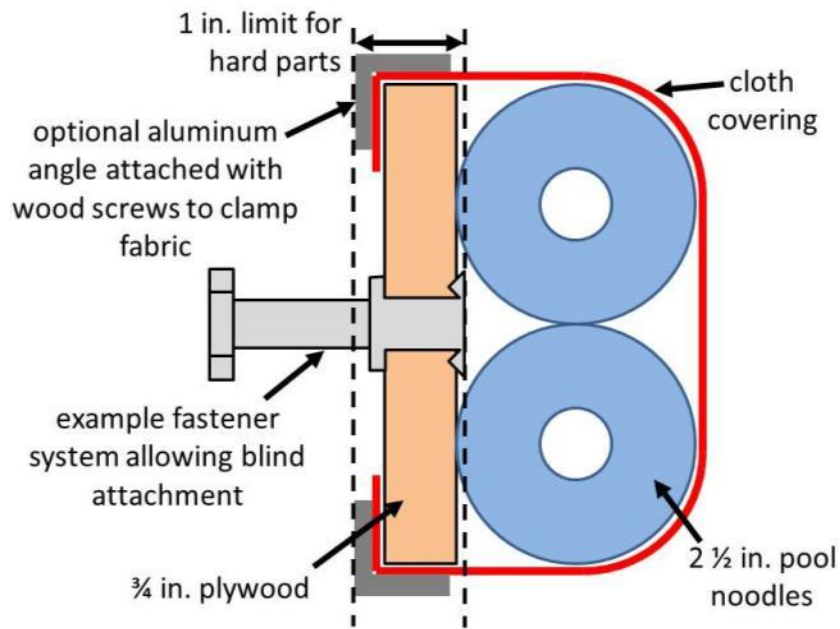


- G. must attach to the FRAME PERIMETER of the ROBOT with a rigid fastening system to form a tight, robust connection to the main structure/frame (e.g. not attached with hook-and-loop, tape, or tie-wraps). The attachment system must be designed to withstand vigorous game play. All removable fasteners (e.g. bolts, locking pins, pip-pins, etc.) will be considered part of the BUMPERS.



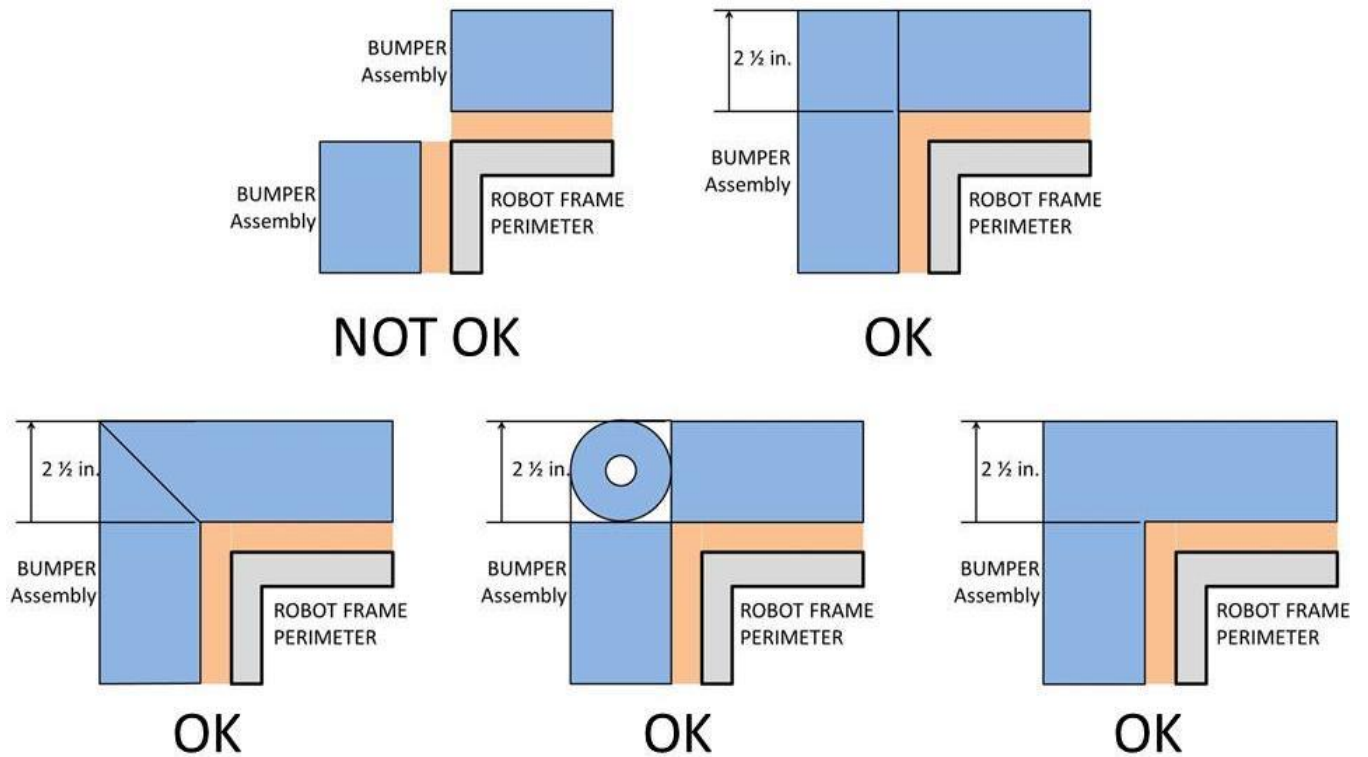


Figure 8-5: BUMPER Vertical Cross Section



R30. Corner joints between BUMPERS must be filled with pool noodle material. Examples of implementation are shown in Figure 8-6.

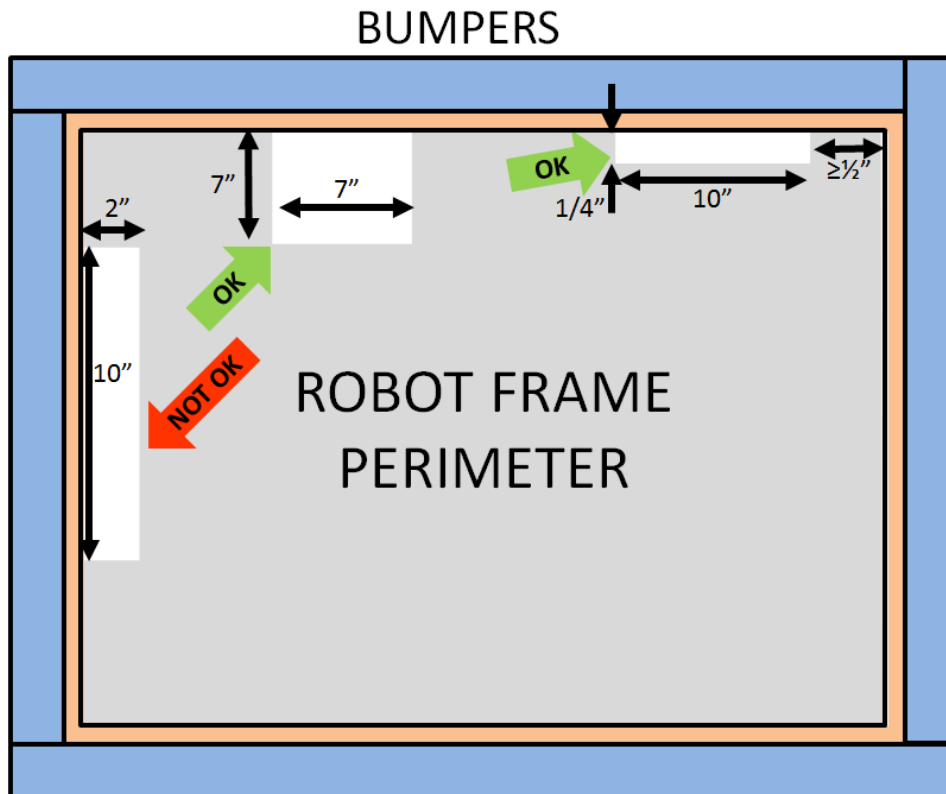
Figure 8-6: Soft Parts of BUMPER Corners





- R31.** BUMPERS must be supported by the structure/frame of the ROBOT (see Figure 8-7). To be considered supported, a minimum of $\frac{1}{2}$ in. (~12.7 mm) at each end of the BUMPER must be backed by the FRAME PERIMETER. Additionally, any gap between the backing material and the frame:
- A. must not be greater than $\frac{1}{4}$ in. (~6 mm) deep, or
 - B. not more than 8 in. (~20 cm) wide

Figure 8-7: BUMPER support examples





8.6 Motors & Actuators

R32. The only motors and actuators permitted on 2017 ROBOTS include the following:

Table 8-1: Motor allowances

Motor Name	Part Numbers Available	Max Qty Allowed
CIM	FR801-001	6
	M4-R0062-12	
	AM802-001A	
	217-2000	
	PM25R-44F-1005	
	PM25R-45F-1004	
	PM25R-45F-1003	
	PMR25R-45F-1003	
PMR25R-44F-1005		
West Coast Products RS775 Pro	217-4347	
Banebots	M7-RS775-18	
	RS775WC-8514	
	M5 – RS550-12	
	RS550VC-7527	
RS550		
AndyMark 9015	am-0912	
VEX BAG	217-3351	
VEX mini-CIM	217-3371	
AndyMark PG	am-2161 (alt. PN am-2765) am-2194 (alt. PN am-2766)	
Select Automotive Motors (Window, Door, Windshield wiper, Seat, Throttle)	Various	Unlimited
Snow Blower Motor	am-2235	
AndyMark NeveRest	am-3104	
Electrical solenoid actuators, no greater than 1 in. (nominal) stroke and rated electrical input power no greater than 10 watts (W) continuous duty at 12 volts (VDC)		
Hard drive motors or fans that are: included in any Kickoff Kit, distributed via FIRST Choice, part of a legal motor controller (including manufacturer provided accessories), or part of a legal COTS computing device		
Factory installed vibration and autofocus motors resident in COTS computing devices (e.g. rumble motor in a smartphone).		
PWM COTS servos with a retail cost < \$75.		
Motors integral to a COTS sensor (e.g. LIDAR, scanning sonar, etc.), provided the device is not modified except to facilitate mounting		

For servos, note that the roboRIO is limited to a max current output of 2.2A on the 6V rail (12.4W of electrical input power). Teams should make sure that their total servo power usage remains below this limit at all times.

This is the total number of each motor a Team may use on their ROBOT, not the quantity per part number. For example, each team may use up to six (6) CIM motors on their ROBOT, regardless of the quantity or combination of each individual part number used.





Given the extensive amount of motors allowed on the ROBOT, Teams are encouraged to consider the total power available from the ROBOT battery during the design and build of the ROBOT. Drawing large amounts of current from many motors at the same time could lead to drops in ROBOT battery voltage that may result in tripping the main breaker or trigger the brownout protection of the roboRIO. For more information about the roboRIO brownout protection and measuring current draw using the PDP, see [RoboRIO Brownout and Understanding Current Draw](#).

- R33.** The integral mechanical and electrical system of any motor must not be modified. Motors, servos, and electric solenoids used on the ROBOT shall not be modified in any way, except as follows:
- A.** The mounting brackets and/or output shaft/interface may be modified to facilitate the physical connection of the motor to the ROBOT and actuated part.
 - B.** The electrical input leads may be trimmed to length as necessary and connectors or splices to additional wiring may be added.
 - C.** The locking pins on the window motors (P/N: 262100-3030 and 262100-3040) may be removed.
 - D.** The connector housings on window, door, windshield wiper or seat motors and Bosch motors (P/N: 6004 RA3 353-01) may be modified to facilitate lead connections.
 - E.** Servos may be modified as specified by the manufacturer (e.g. re-programming or modification for continuous rotation).

The intent of this rule is to allow teams to modify mounting tabs and the like, not to gain a weight reduction by potentially compromising the structural integrity of any motor. The integral mechanical and electrical system of the motor is not to be modified.

Note that for the previous KOP Window motors and the Bosch motor, the gearbox is considered integral to the motor, thus the motor may not be used without the gearbox.

- R34.** With the exception of servos, fans, or motors integral to sensors of COTS computing devices permitted in R32, each actuator must be controlled by a power regulating device. The only power regulating devices for actuators permitted on the ROBOT include:
- A.** Motor Controllers
 - i.** DMC 60 Motor Controller (P/N: 410-334-1)
 - ii.** Jaguar Motor Controller (P/N: MDL-BDC, MDL-BDC24, and 217-3367)
 - iii.** SD540 Motor Controller (P/N: SD540x1, SD540x2, SD540x4, SD540Bx1, SD540Bx2, SD540Bx4, SD540C)
 - iv.** Spark Motor Controller (P/N: REV-11-1200)
 - v.** Talon Motor Controller (P/N: CTRE_Talon, CTRE_Talon_SR, and am-2195)
 - vi.** Talon SRX Motor Controller (P/N: 217-8080, am-2854, 14-838288), equipped with firmware version 0.28 or newer if using via PWM. See R75 if using via CAN.
 - vii.** Victor 884 Motor Controller (P/N: VICTOR-884-12/12)
 - viii.** Victor 888 Motor Controller (P/N: 217-2769)





ix. Victor SP Motor Controller (P/N: 217-9090, am-2855, 14-868380)

B. Relay Modules

i. Spike H-Bridge Relay (P/N: 217-0220 and SPIKE-RELAY-H)

C. Pneumatics controllers

i. Pneumatics Control Module (P/N: am-2858, 217-4243)

Please see the [Talon SRX User Guide](#) for more information about the Talon SRX firmware update, determining the firmware on your Talon SRX, and instructions on how install.

R35. Each power regulating device may control electrical loads per Table 8-2. Unless otherwise noted, each power regulating device shall control one and only one electrical load.

Table 8-2: Power regulating device allotments

Electrical Load	Motor Controller	Relay Module	Pneumatics Controller
CIM AndyMark 9015 WCP RS775 Pro VEX BAG/MiniCIM	Yes	No	No
Automotive Window/Door/Windshield Wiper/Seat/Throttle Motors AndyMark PG Snow-Blower Motor	Yes (up to 2 per controller)	Yes	No
Compressor	No	Yes	Yes
Pneumatic Solenoid Valves	No	Yes*	Yes (1 per channel)
Electric Solenoids	No	Yes*	Yes (1 per channel)
CUSTOM CIRCUITS ^a	Yes	Yes*	Yes (1 per channel)

* Multiple low-load, pneumatic solenoid valves, electric solenoids or CUSTOM CIRCUITS may be connected to a single relay module. This would allow one (1) relay module to drive multiple pneumatic actions or multiple CUSTOM CIRCUITS. No other electrical load can be connected to a relay module used in this manner.

^a A CUSTOM CIRCUIT is any electrical COMPONENT of the ROBOT other than motors, pneumatic solenoids, roboRIO, PDP, PCM, VRM, RSL, 120A breaker, motor controllers, relay modules, wireless bridge, or batteries.

R36. Servos must be connected to, and only to, one of the following:

- A. PWM ports on the roboRIO
- B. PWM ports on a WCP Spartan Sensor Board (P/N: WCP-0045)
- C. REV Servo Power Module (P/N: REV-11-1144)



8.7 Power Distribution

- R37.** The only legal source of electrical energy for the ROBOT during the competition, the ROBOT battery, must be a non-spillable sealed lead acid (SLA) battery with the following specifications:
- A.** Nominal voltage: 12V
 - B.** Nominal capacity at 20-hour discharge rate: minimum 17Ah, maximum 18.2Ah
 - C.** Shape: Rectangular
 - D.** Nominal Dimensions: 7.1 in. x 3 in. x 6.6 in., +/- .1 in. for each dimension (~ 180 mm x 76mm x 168 mm, +/- 2.5 mm for each dimension)
 - E.** Nominal weight: 11lbs. to 14.5 lbs. (~5 kg. to 6.5 kg.)
 - F.** Terminals: Nut and bolt style

Examples of batteries which meet these criteria include:

- A.** Energys (P/N: NP18-12, NP18-12B, NP18-12BFR)
- B.** MK Battery (P/N: ES17-12)
- C.** Battery Mart (P/N: SLA-12V18)
- D.** Sigma (P/N: SP12-18)
- E.** Universal Battery (P/N: UB12180)
- F.** Power Patrol (P/N: SLA1116)
- G.** Werker Battery (P/N: WKA12-18NB)
- H.** Power Sonic (P/N: PS-12180NB)
- I.** Yuasa (P/N: NP18-12B)
- J.** Panasonic (P/N: LC-RD-1217)
- K.** Interstate Batteries (P/N: BSL1116)
- L.** Duracell Ultra Battery (P/N: DURA12-18NB)

Teams should be aware that they may be asked to provide documentation of the specifications of any battery not listed above.

Batteries should be charged in accordance with manufacturer's specification. (Please see the [FIRST Safety Manual](#) for additional information.)

Additionally, batteries integral to and part of a COTS computing device or self-contained camera are also permitted (e.g. laptop batteries, GoPro style camera, etc.), provided they're only used to power the COTS computing device and any peripheral COTS USB input devices connected to the COTS computing device and they are securely fastened to the ROBOT.

- R38.** Any battery charger used to charge a ROBOT battery must have the corresponding Anderson SB connector installed.
- R39.** Any battery charger used to charge a ROBOT battery may not be used such that it exceeds 6-Amp charge current.





R40. No batteries other than those allowed per R37 are allowed on the ROBOT, whether or not they are being used to supply power.

This means teams may not use additional batteries as extra weight on their ROBOTS, for example.

R41. The ROBOT battery must be secured such that it will not dislodge should the ROBOT be turned over or placed in any arbitrary orientation.

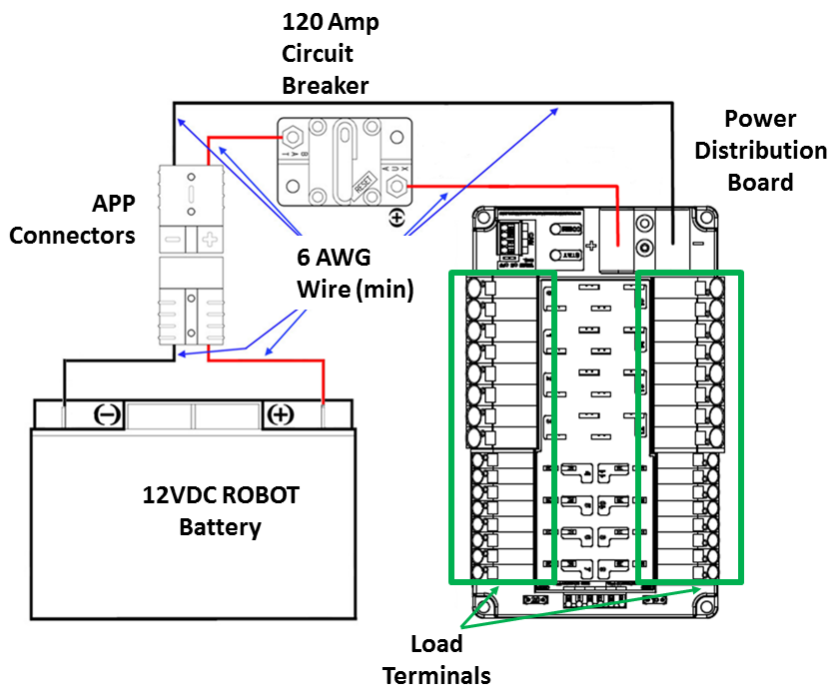
R42. Each electrical terminal on the ROBOT battery, main breaker, and their connections (lugs, stripped wire ends, etc.) to the wire must be fully insulated at all times.

R43. Non-electrical sources of energy used by the ROBOT, (i.e., stored at the start of a MATCH), shall come only from the following sources:

- A. compressed air stored in the pneumatic system that has been charged in compliance with R84 and R85,
- B. a change in the altitude of the ROBOT center of gravity,
- C. storage achieved by deformation of ROBOT parts,
- D. closed-loop COTS pneumatic (gas) shocks, and
- E. air-filled (pneumatic) wheels.

R44. The one (1) ROBOT battery, a single pair of Anderson Power Products (or APP) 2-pole SB type connectors, the one (1) main 120-amp (120A) circuit breaker (Cooper Bussman P/N: CB185-120), and the one (1) CTR Electronics Power Distribution Panel (PDP, P/N: am-2856, 217-4244) shall be connected with 6 AWG (7 SWG or 16 mm²) wire or larger, with no additional devices or modifications, as shown in Figure 8-8.

Figure 8-8: Electrical connection diagram





“SB type” refers to SB type only (e.g. SB-50, SB-120, etc.), not SBS or any other part type beginning with SB. All batteries supplied by *FIRST* (such as Spare Parts and international batteries) will have a Red or Pink SB50 connector installed which may not be removed.

The pink connectors included in the 2017 KOP mate with the Red SB50 connector.

R45. All circuits, with the exceptions of those listed in R50 and R52, must connect to, and have power sourced solely by, a single protected 12VDC WAGO connector pair (i.e. the Load Terminals, as shown in Figure 8-8) of the one (1) CTR Electronics Power Distribution Panel, not the M6 cap screws.

R46. All wiring and electrical devices, including all Control System COMPONENTS, shall be electrically isolated from the ROBOT frame. The ROBOT frame must not be used to carry electrical current.

R46 is checked by observing a $>3k\Omega$ resistance between either the (+) or (-) post within the APP connector that is attached to the PDP and any point on the ROBOT.

The Victor-SP and Talon-SRX motor controller cases are electrically isolated. They may be mounted directly to ROBOT frame COMPONENTS.

Note that some cameras and sensors (e.g. the Axis 206 camera) have grounded enclosures. These devices must be electrically isolated from the ROBOT frame to ensure compliance with R46.

R47. The 120A circuit breaker must be quickly and safely accessible from the exterior of the ROBOT. This is the only 120A circuit breaker allowed on the ROBOT.

Examples considered not “quickly and safely accessible” include breakers covered by an access panel or door, or mounted on, underneath or immediately adjacent to moving components.

It is strongly recommended that the 120A circuit breaker location be clearly and obviously labeled so it can be easily found by FIELD STAFF during a MATCH.

R48. The PDP, associated wiring, and all circuit breakers must be easily visible for Inspection.

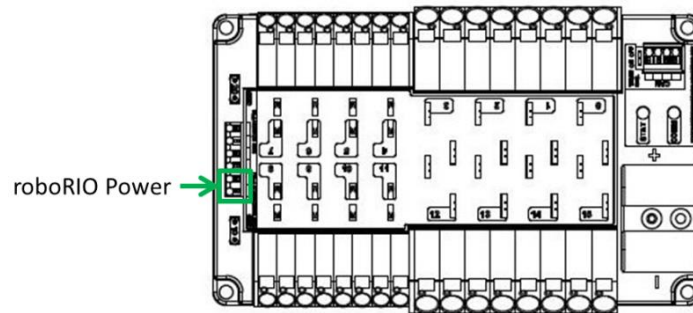
R49. Any active electrical item that is not an actuator (specified in R32) or core Control System item (specified in R71) is considered a CUSTOM CIRCUIT. CUSTOM CIRCUITS shall not produce voltages exceeding 24V.

R50. The roboRIO power input must be connected to the dedicated supply terminals on the PDP shown in Figure 8-9. No other electrical load shall be connected to these terminals.



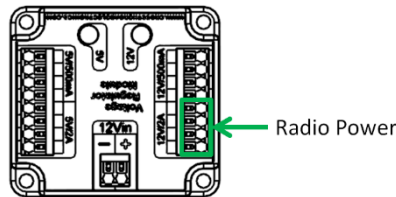


Figure 8-9: roboRIO power source



- R51.** The Wireless Bridge power must be supplied directly by the 12V 2A output of a CTR Electronics Voltage Regulator Module (VRM) (P/N: am-2857, 217-4245) and must be the only load connected to those terminals.

Figure 8-10: Radio power source



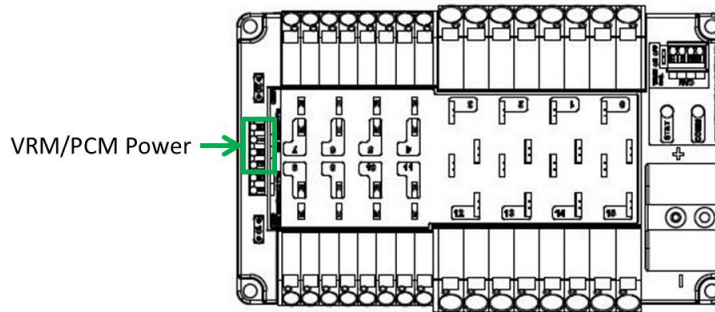
Note that this wiring is different from the wiring for the radio used in 2015, but is identical to the wiring from 2016. When using a 2015 VRM with the OM5P-AN or OM5P-AC radio, the radio should be connected as described above, not to the terminals labeled “Radio”.

Note that this prohibits using any active POE Injector device to power the radio, but does not prohibit using any PASSIVE CONDUCTORS to inject the VRM power into an Ethernet cable plugged into the radio port labeled “18-24v POE”.

- R52.** The VRM supplying power to the Wireless Bridge per R51 must be connected to the designated supply terminals at the end of the PDP, and not the main WAGO connectors along the sides of the PDP as shown in Figure 8-11. With the exception of a single CTR Electronics Pneumatics Control Module (PCM, P/N: am-2858), no other electrical load shall be connected to these PDP terminals.



Figure 8-11: VRM and PCM power source



Please reference [Wiring the 2016 FRC Control System for Wireless Bridge](#) wiring information.

R53. Only one wire shall be connected to each WAGO connector on the PDP.

If multi-point distribution of circuit power is needed (e.g. to provide power to multiple PCMs and/or VRMs from one 20A circuit), then all incoming wires may be appropriately spliced into the main lead (e.g. using an insulated terminal block, crimped splice or soldered wire splice), and the single main lead inserted into the WAGO connector to power the circuit.

R54. The only circuit breakers permitted for use in the PDP are:

- A. Snap Action VB3-A Series, terminal style F57
- B. Snap Action MX5-A Series, 40A rating or lower

R55. The fuses in the PDP shall only be replaced with functionally identical fuses (mini automotive blade fuses with values matching those printed on the PDP)

R56. Each branch circuit must be protected by one and only one circuit breaker on the PDP per Table 8-3. No other electrical load can be connected to the breaker supplying this circuit.

Table 8-3: Branch circuit protection requirements

Branch Circuit	Circuit Breaker Value	Quantity Allowed Per Breaker
Motor Controller	Up to 40A	1
CUSTOM CIRCUIT	Up to 40A	1
Fans permitted per Table 8-1 and not already part of COTS computing devices	Up to 20A	No limit
Relay Module	Up to 20A	1
PCM – with compressor	20A	1
Additional VRM (non-radio)/Additional PCM (non-compressor)	20A	3 total



R56 does not prohibit the use of smaller value breakers in the PDP or any fuses or breakers within CUSTOM CIRCUITS for additional protection.

R57. All circuits shall be wired with appropriately sized insulated wire:

Table 8-4: Wire sizes

Application	Minimum Wire Size
31 – 40A protected circuit	12 AWG (13 SWG or 4 mm ²)
21 – 30A protected circuit	14 AWG (16 SWG or 2.5 mm ²)
6 – 20A protected circuit	18 AWG
Between the PDP dedicated terminals and the VRM or PCM Compressor outputs from the PCM	(19 SWG or 1 mm ²)
Between the PDP and the roboRIO	22 AWG
VRM 2A circuits	(22 SWG or 0.5 mm ²)
≤5A protected circuit	26 AWG
roboRIO PWM port outputs	(27 SWG or 0.14 mm ²)
SIGNAL LEVEL circuits (i.e. circuits which draw ≤1A continuous and have a source incapable of delivering >1A, including but not limited to roboRIO non-PWM outputs, CAN signals, PCM Solenoid outputs, VRM 500mA outputs and Arduino outputs)	28 AWG (29 SWG or .08 mm ²)

Wires that are recommended by the device manufacturer or originally attached to legal devices are considered part of the device and by default legal. Such wires are exempt from R57.

- R58.** Branch circuits may include intermediate elements such as COTS connectors, splices, COTS flexible/rolling/sliding contacts, and COTS slip rings, as long as the entire electrical pathway is via appropriately gauged/rated elements.
- R59.** All non-SIGNAL LEVEL wiring with a constant polarity (i.e., except for outputs of relay modules, motor controllers, or sensors) shall be color-coded along their entire length from the manufacturer as follows:

- A.** Red, yellow, white, brown, or black-with-stripe on the positive (e.g. +24VDC, +12VDC, +5VDC, etc.) connections
- B.** Black or blue for the common or negative side (-) of the connections.

Wires that are originally attached to legal devices are considered part of the device and by default legal. Such wires are exempt from R59.

R60. CUSTOM CIRCUITS shall not directly alter the power pathways between the ROBOT battery, PDP, motor controllers, relays, motors and actuators (per R32), pneumatic solenoid valves, or other elements of the ROBOT control system (items explicitly mentioned in R71). Custom high impedance voltage monitoring or low impedance current monitoring circuitry connected to the ROBOT'S electrical system is acceptable, if the effect on the ROBOT outputs is inconsequential.

A noise filter may be wired across motor leads or PWM leads. Such filters will not be considered CUSTOM CIRCUITS and will not be considered a violation of R60 or R77.

Acceptable signal filters must be fully insulated and must be one of the following:



A one microfarad (1 μ F) or less, non-polarized, capacitor may be applied across the power leads of any motor on your ROBOT (as close to the actual motor leads as reasonably possible).

A resistor may be used as a shunt load for the PWM control signal feeding a servo.

8.8 Control, Command & Signals System

- R61.** ROBOTS must be controlled via one (1) programmable National Instruments roboRIO (P/N: am3000), with image version FRC_2017_v8.

There are no rules that prohibit co-processors, provided commands originate from the roboRIO to configure, enable, and specify all operating points for all power regulating devices. This includes motor controllers legally wired to the CAN-bus.

- R62.** One (1) OpenMesh Wireless Bridge (P/N: OM5P-AN or OM5P-AC), that has been configured with the appropriate encryption key for your team number at each event, is the only permitted device for communicating to and from the ROBOT during the MATCH.
- R63.** The roboRIO Ethernet port must be connected to the Wireless Bridge port labeled “18-24 vPOE,” closest to the power connector (either directly or via a CAT5 Ethernet pigtail).
- R64.** Ethernet-connected COTS devices or CUSTOM CIRCUITS may connect to any remaining Ethernet port on the Wireless Bridge but must not transmit or receive UDP packets using ports 1100-1200 with the exception of ports 1130 and 1140.
- R65.** Communication between the ROBOT and the OPERATOR CONSOLE is restricted as follows:

A. Network Ports:

- i.** UDP/TCP 1180-1190: Camera data from the roboRIO to the Driver Station (DS) when the camera is connected the roboRIO via USB, bi-directional.
- ii.** TCP 1735: SmartDashboard, bi-directional
- iii.** UDP 1130: Dashboard-to-ROBOT control data, uni-directional
- iv.** UDP 1140: ROBOT-to-Dashboard status data, uni-directional
- v.** HTTP 80: Camera connected via switch on the ROBOT, bi-directional
- vi.** HTTP 443: Camera connected via switch on the ROBOT, bi-directional
- vii.** UDP/TCP 554: Real-Time Streaming Protocol for h.264 camera streaming, bi-directional
- viii.** UDP/TCP 5800-5810: Team Use, bi-directional

Teams may use these ports as they wish if they do not employ them as outlined above (i.e. TCP 1180 can be used to pass data back and forth between the ROBOT and the DS if the Team chooses not to use the camera on USB).

B. Bandwidth: no more than 7 Mbits/second.

Note that, for 2017, the 7 Mbit limit will be strictly enforced by the Wireless Bridge.

The [FMS Whitepaper](#) has more details on how to check and optimize bandwidth usage.

While *FIRST*[®] makes every effort to provide a wireless environment that allows teams access to a full 7 Mbits/second data rate (with about 100





Kbit used for ROBOT control and status), at some events wireless conditions may not accommodate this.

- R66.** The roboRIO, Driver Station software, and Wireless Bridge must be configured to correspond to the correct Team number, per the procedures defined in [Getting Started with the 2017 Control System](#).
- R67.** All signals must originate from the OPERATOR CONSOLE and be transmitted to the ROBOT via the ARENA Ethernet network.
- R68.** No form of wireless communication shall be used to communicate to, from, or within the ROBOT, except those required per R62 and R67.

Devices that employ signals in the visual spectrum (e.g. cameras) and non-RF sensors that don't receive human-originated commands (e.g. "beam break" sensors or IR sensors on the ROBOT used to detect FIELD elements) aren't wireless communication devices and thus R68 doesn't apply.

- R69.** The Wireless Bridge must be mounted on the ROBOT such that the diagnostic lights are visible to ARENA personnel.

Teams are encouraged to mount the wireless bridge away from noise generating devices such as motors, PCM(s), and VRM(s).

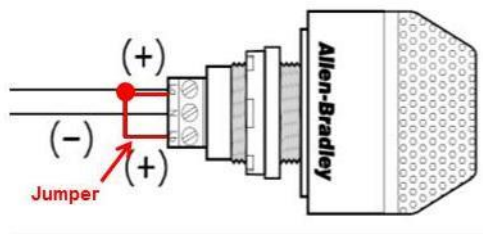
- R70.** ROBOTS must use at least one (1), but no more than two (2), diagnostic Robot Signal Lights (RSL) (P/N: 855PB-B12ME522).

Any RSL must be:

- A.** mounted on the ROBOT such that it is easily visible while standing three 3 ft. (~ 100 cm) in front of the ROBOT,
- B.** connected to the "RSL" supply terminals on the roboRIO,
- C.** wired for solid light operation, by placing a jumper between the "La" and "Lb" terminals on the light per Figure 8-12.

Please see [Wiring the 2017 FRC Control System](#) for connection details.

Figure 8-12: RSL jumper wiring





- R71.** The Driver Station software, roboRIO, Power Distribution Panel, Pneumatics Control Modules, Voltage Regulator Modules, RSL, 120A breaker, motor controllers, relay modules, Wireless Bridge, and batteries shall not be tampered with, modified, or adjusted in any way (tampering includes drilling, cutting, machining, rewiring, disassembling, etc.), with the following exceptions:

Please note that the Driver Station application is a separate application from the Dashboard. The Driver Station software may not be modified, while teams are expected to customize their Dashboard code.

- A. User programmable code in the roboRIO may be customized.
- B. Motor controllers may be calibrated as described in owner's manuals.
- C. Fans may be attached to motor controllers and may be powered from the power input terminals.
- D. If powering the compressor, the fuse on a Spike H-Bridge Relay may be replaced with a 20A Snap-Action circuit breaker.
- E. Wires, cables, and signal lines may be connected via the standard connection points provided on the devices.
- F. Fasteners (including adhesives) may be used to attach the device to the OPERATOR CONSOLE or ROBOT or to secure cables to the device.
- G. Thermal interface material may be used to improve heat conduction.
- H. Labeling may be applied to indicate device purpose, connectivity, functional performance, etc.
- I. Jumpers may be changed from their default location.
- J. Limit switch jumpers may be removed from a Jaguar motor controller and a custom limit switch circuit may be substituted.
- K. Device firmware may be updated with manufacturer supplied firmware.
- L. Integral wires on the Victor SP or Talon SRX may be cut, stripped, and/or connectorized.
- M. Devices may be repaired, provided the performance and specifications of the device after the repair are identical to those before the repair.
- N. The cover may be removed from the Talon SRX data port.

Please note that while repairs are permitted, the allowance is independent of any manufacturer's warranty. Teams make repairs at their own risk and should assume that any warranty or RMA options are forfeited. Be aware that diagnosing and repairing COMPONENTS such as these can be difficult.

- R72.** Neither 12VDC power nor relay module or motor controller outputs shall be directly connected to the roboRIO (with the exception of the designated 12VDC input).
- R73.** Every relay module, servo controller, and PWM motor controller shall be connected to a corresponding port (relays to Relay ports, servo controllers and PWM controllers to PWM ports) on the roboRIO (either directly or through a WCP Spartan Sensor Board) or via a legal MXP connection (per R74). They shall not be controlled by signals from any other source.
- R74.** If a motor is controlled via the MXP, its power regulating device must be connected by one of the following methods:
- A. directly to any PWM pins,





- B. via a network of PASSIVE CONDUCTORS used to extend the PWM pins, or
- C. via one approved ACTIVE DEVICE:
 - ix. Kauai Labs navX MXP
 - x. RCAL MXP Daughterboard
 - xi. REV Robotics RIOduino
 - xii. REV Robotics Digit Board
 - xiii. WCP Spartan Sensor Board
 - xiv. Huskie Robotics HUSKIE 2.0 Board

A PASSIVE CONDUCTOR is any device or circuit whose capability is limited to the conduction and/or static regulation of the electrical energy applied to it (e.g. wire, splices, connectors, printed wiring board, etc.).

An ACTIVE DEVICE is any device capable of dynamically controlling and/or converting a source of electrical energy by the application of external electrical stimulus.

The “network of PASSIVE CONDUCTORS” only applies to the pins being used for PWM output to motors or servos. This means that connecting an ACTIVE DEVICE, such as a sensor to one MXP pin does not prevent other MXP pins from being used in accordance with R74-B.

- R75.** Each Jaguar or Talon SRX must be controlled with signal inputs sourced from the roboRIO and passed via either a PWM (wired per R73) or CAN-bus (either directly or daisy-chained via another CAN-bus device) signal, but both shall not be wired simultaneously on the same device. If the CAN-bus configuration is used, the firmware on the device must be updated to at least the following versions:
- A. Grey Jaguars – v109
 - B. Black Jaguars – v109
 - C. Talon SRX – v1.01.

As long as the CAN bus is wired legally so that the heartbeat from the roboRIO is maintained, all closed loop control features of the Jaguar or Talon SRX motor controller may be used. (That is, commands originating from the roboRIO to configure, enable, and specify an operating point for all Jaguar or Talon SRX closed loop modes fit the intent of R61.)

- R76.** Each PCM must be controlled with signal inputs sourced from the roboRIO and passed via a CAN-bus connection from the roboRIO (either directly or daisy-chained via another CAN-bus device). The firmware on each PCM must be updated to at least version 1.62.
- R77.** The PDP CAN interface must be connected to the CAN-bus on the roboRIO (either directly or daisy-chained via another CAN-bus device).

For documentation on how to wire the CAN-bus connections of the PDP see [Wiring the 2017 FRC Control System](#).

- R78.** The CAN-bus must be connected to the roboRIO CAN port.
- A. Additional switches, sensor modules, CUSTOM CIRCUITS, third-party modules, etc. may also be placed on the CAN-bus.





- B. No device that interferes with, alters, or blocks communications among the roboRIO and the Jaguars, PDP, PCMs, and/or Talon-SRXs on the bus will be permitted.

Only one wire should be inserted into each Weidmuller CAN connector terminal. For documentation on how to wire the CAN-bus connections of the roboRIO, PCM, PDP and CAN motor controllers, see [Wiring the 2017 FRC Control System](#).

8.9 Pneumatic System

- R79. To satisfy multiple constraints associated with safety, consistency, Inspection, and constructive innovation, no pneumatic parts other than those explicitly permitted in [Section 8.9 Pneumatic System](#) shall be used on the ROBOT.

- R80. All pneumatic items must be COTS pneumatic devices rated by their manufacturers for burst or maximum pressure of at least 125psi (~862 kPa).

It is recommended that all pneumatic items be rated by their manufacturers for a working pressure of at least 60 psi (~414 kPa).

- R81. All pneumatic COMPONENTS must be used in their original, unaltered condition. Exceptions are as follows:

- A. tubing may be cut,
- B. wiring for pneumatic devices may be modified to interface with the control system,
- C. assembling and connecting pneumatic COMPONENTS using the pre-existing threads, mounting brackets, quick-connect fittings, etc.,
- D. removing the mounting pin from a pneumatic cylinder, provided the cylinder itself is not modified,
- E. labeling applied to indicate device purpose, connectivity, functional performance, etc.

Do not, for example, paint, file, machine, or abrasively remove any part of a pneumatic COMPONENT – this would cause the part to become a prohibited item. Consider pneumatic COMPONENTS sacred.

- R82. The only pneumatic system items permitted on ROBOTS include the items listed below.

- A. Items available in the KOP (except as noted in K),
- B. Pneumatic pressure vent plug valves functionally equivalent to those provided in the KOP,

Parker valves PV609-2 or MV709-2 are recommended.

- C. Pressure relief valves functionally equivalent to those provided in the KOP,

Norgren 16-004-011, 16-004-003 or McMaster-Carr 48435K71 recommended.

To be considered functionally equivalent the valve must be preset or adjustable to 125 psi (~862 kPa) and capable of relieving at least 1 scfm (~472 cm³/s).

- D. Solenoid valves with a maximum 1/8 in. (nominal) NPT, BSPP, or BSPT port diameter,





- E. Additional pneumatic tubing, with a maximum 0.165 in. (nominal) inside diameter, functionally equivalent to that provided in the KOP,
- F. Pressure transducers, pressure gauges, passive flow control valves (specifically “needle valve”), manifolds, and connecting fittings,
- G. Check and quick exhaust valves, provided that the requirements of R94 are still met.
- H. Shutoff valves which relieve downstream pressure to atmosphere when closed (may also be known as 3-way or 3-way exhausting valves).
- I. Pressure regulators with the maximum outlet pressure adjusted to no more than 60 psi (~413 kPa),
- J. Pneumatic cylinders, pneumatic linear actuators, and rotary actuators,
- K. Pneumatic storage tanks (with the exception of White Clippard tanks P/N: AVT-PP-41), and
- L. Compressors compliant with R84.

The following devices are not considered pneumatic devices and are not subject to pneumatic rules (though they must satisfy all other rules):

- A. a device that creates a vacuum
- B. closed-loop COTS pneumatic (gas) shocks
- C. air-filled (pneumatic) wheels

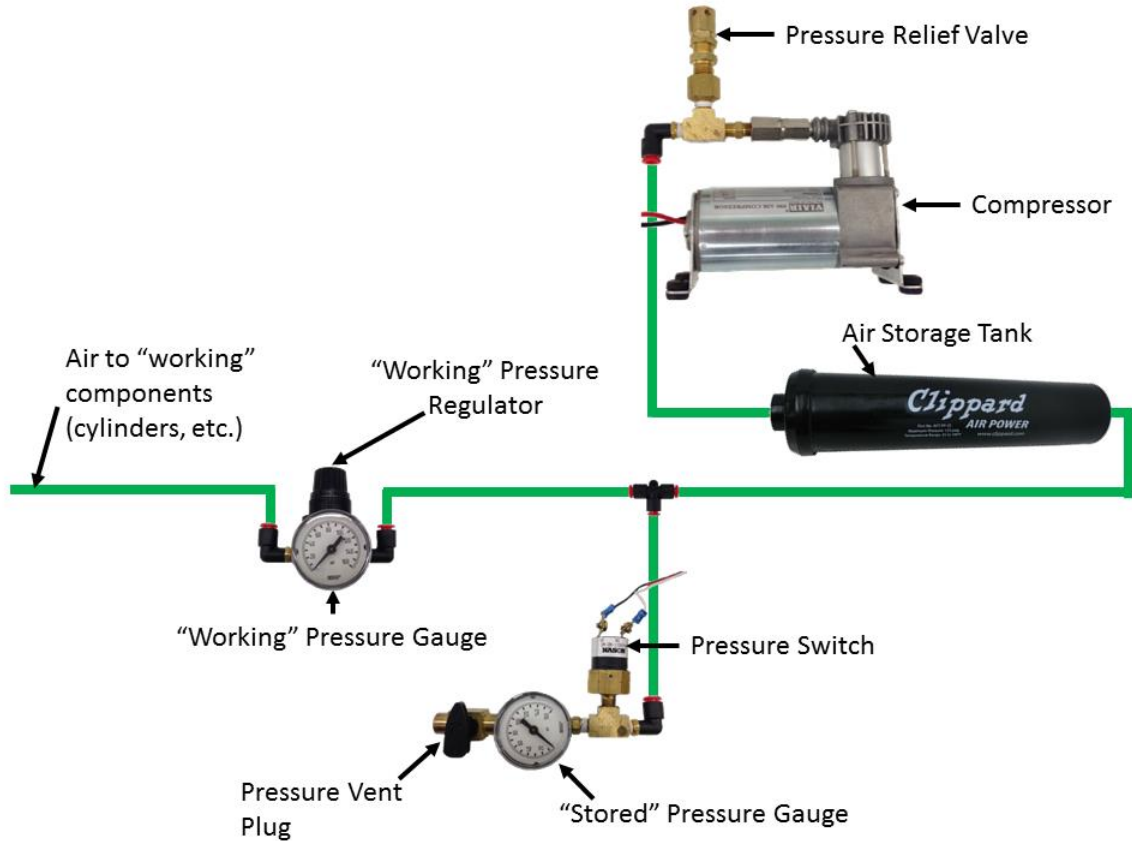
R83. If pneumatic COMPONENTS are used, the following items are required as part of the pneumatic circuit and must be used in accordance with this section, as illustrated in Figure 8-13.

- A. Compressor
- B. Pressure relief valve (per R82-C) connected via legal rigid fittings (e.g. brass, nylon, etc.)
- C. Nason pressure switch, P/N SM-2B-115R/443
- D. At least one Pressure vent plug
- E. “Stored” pressure gauge (upstream from Primary Regulator, must show psi)
- F. “Working” pressure gauge (downstream from Primary Regulator, must show psi)
- G. “Working” pressure regulator





Figure 8-13: Pneumatic circuitry



- R84.** Compressed air on the ROBOT must be provided by one and only one compressor. Compressor specifications must not exceed nominal 1.10 cfm (~519 cm³/s) flow rate @ 12VDC.
- R85.** The compressor (permitted per R84) may be located off-board the ROBOT, however the compressor must still be controlled and powered by the ROBOT when used.

The compressor may be mounted on the ROBOT, or it may be left off the ROBOT and used to pre-charge compressed air in storage tanks on the ROBOT provided the additional restrictions of R90 are met.

The intent of this rule is to permit teams to take advantage of the weight savings associated with keeping the compressor off-board. However, using the compressor off-board of the ROBOT does NOT permit non-compliance with any other applicable rules.

- R86.** “Stored” air pressure on the ROBOT must be no greater than 120 psi (~827 kPa). No stored air pressure intended for the ROBOT may be located off-board the ROBOT.
- R87.** “Working” air pressure on the ROBOT must be no greater than 60 psi (~413 kPa) and must be provided through a single primary adjustable, relieving, pressure regulator.

Norgren regulator P/N: R07-100-RNEA or Monnier P/N: 101-3002-1 recommended.

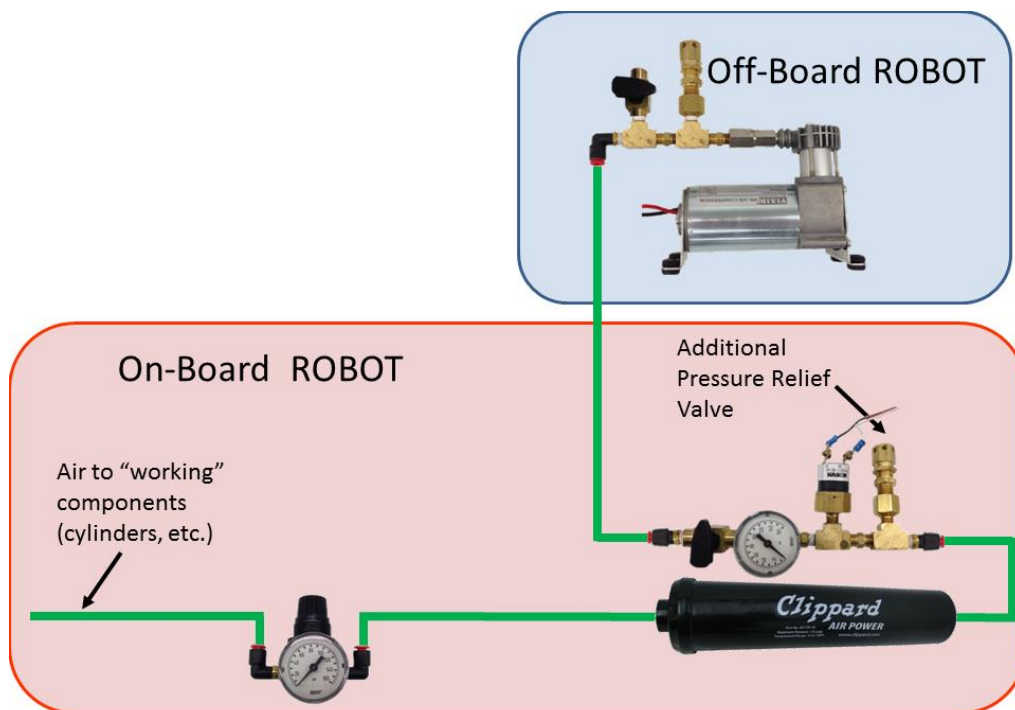


- R88.** Only the compressor, relief valve (P/N: 16-004-011 or 16-004-003), pressure switch, pressure vent plug, pressure gauge, storage tanks, tubing, pressure transducers, and connecting fittings may be in the high-pressure pneumatic circuit upstream from the regulator.

It is recommended that all COMPONENTS in the high-pressure pneumatic circuit upstream from the regulator be rated for at least 115 psi (~793 kPa) working pressure.

- R89.** Pressure gauges must be placed in easily visible locations upstream and downstream of the regulator to display the “stored” and “working” pressures.
- R90.** If the compressor is not included on the ROBOT (under the provisions of R85) the “stored” pressure gauge and pressure switch may be located on-board (Figure 8-14) or off-board (Figure 8-15) (but must be together), provided all other pneumatic rules are satisfied.

Figure 8-14: Off board compressor with stored pressure gauge and pressure switch on the ROBOT

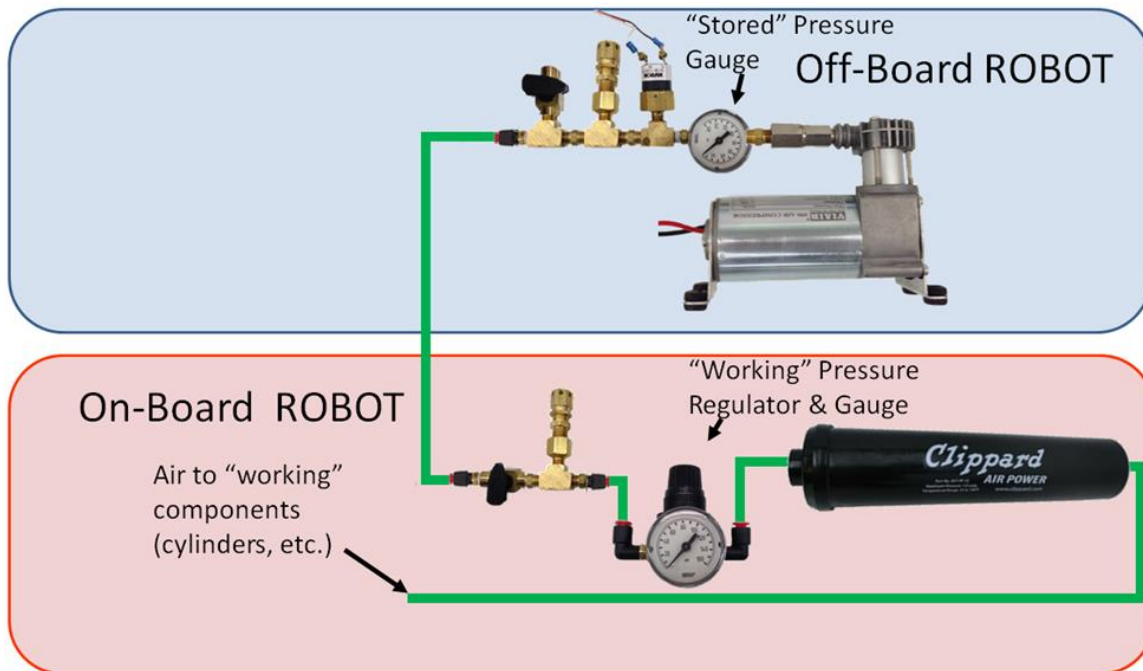


- R91.** If the stored pressure gauge is kept off-board the ROBOT with the compressor, then only low-pressure (60 psi (~413 kPa) or less) “working” air can be stored on the ROBOT. The “working” pressure gauge must be installed on-board the ROBOT at all times (Figure 8-15).





Figure 8-15: Off board compressor with stored pressure gauge and pressure switch off the ROBOT



R92. The relief valve must be attached directly to the compressor or attached by legal hard fittings (e.g. brass, nylon, etc.) connected to the compressor output port. If using an off-board compressor, an additional relief valve must be included on the ROBOT.

If necessary, Teams are required to adjust the relief valve to release air at 125 psi (~861 kPa). The valve may or may not have been calibrated prior to being supplied to Teams.

R93. The pressure switch requirements are:

- A. It must be Nason P/N: SM-2B-115R/443
- B. It must be connected to the high-pressure side of the pneumatic circuit (i.e. prior to the pressure regulator) to sense the “stored” pressure of the circuit.
- C. The two wires from the pressure switch must be connected directly to the pressure switch input of the PCM controlling the compressor or, if controlled using the roboRIO and a Spike relay, to the roboRIO.
- D. If connected to the roboRIO, the roboRIO must be programmed to sense the state of the switch and operate the relay module that powers the compressor to prevent over-pressuring the system.

R94. Any pressure vent plug must be:

- A. connected to the pneumatic circuit such that, when manually operated, it will vent to the atmosphere to relieve all stored pressure in a reasonable amount of time, and
- B. placed on the ROBOT so that it is visible and easily accessible.

If the compressor is not used on the ROBOT, then an additional pressure vent plug must be connected to the high-pressure portion of the pneumatic circuit off-board the ROBOT with the compressor (see R85).

R95. The outputs from multiple solenoid valves must not be plumbed together.





8.10 OPERATOR CONSOLE

- R96.** The Driver Station software provided on the [National Instruments website](#) is the only application permitted to specify and communicate the operating mode (i.e. Autonomous/Teleop) and operating state (Enable/Disable) to the ROBOT. The DRIVER Station software must be revision 17.0a11 or newer.

Teams are permitted to use a portable computing device of their choice (laptop computer, tablet, etc.) to host the DRIVER Station software while participating in competition MATCHES.

- R97.** The OPERATOR CONSOLE, the set of COMPONENTS and MECHANISMS used by the DRIVERS and/or HUMAN PLAYER to relay commands to the ROBOT, must include a graphic display to present the Driver Station diagnostic information. It must be positioned within the OPERATOR CONSOLE so that the screen display can be clearly seen during Inspection and in a MATCH.
- R98.** Devices hosting the Driver Station software must only interface with the Field Management System (FMS) via the Ethernet cable provided at the PLAYER STATION (e.g. not through a switch). Teams may connect the FMS Ethernet cable to their Driver Station device directly via an Ethernet pigtail, or with a single-port Ethernet converter (e.g. docking station, USB-Ethernet converter, Thunderbolt-Ethernet converter, etc.). The Ethernet port on the OPERATOR CONSOLE must be easily and quickly accessible.

Teams are strongly encouraged to use pigtails on the Ethernet port used to connect to the FMS. Such pigtails will reduce wear and tear on the device's port and, with proper strain relief employed, will protect the port from accidental damage.

- R99.** The OPERATOR CONSOLE must not
- A.** be longer than 60 in. (~152 cm)
 - B.** be deeper than 14 in. (~35 cm) (excluding any items that are held or worn by the DRIVERS during the MATCH)
 - C.** extend more than 6 ft. 6 in. (~198 cm) above the floor
 - D.** attach to the FIELD (except as permitted by G15)

There is a 54 in. (~137 cm) long by 2 in. (nominal) wide strip of hook-and-loop tape ("loop" side) along the center of the PLAYER STATION support shelf that may be used to secure the OPERATOR CONSOLE to the shelf, per G15. See [Section 3.11.1 PLAYER STATION](#) for details.

Please note that while there is no hard weight limit, OPERATOR CONSOLES that weigh more than 30 lbs. (~13 kg.) will invite extra scrutiny as they are likely to present unsafe circumstances.

- R100.** Other than the system provided by the ARENA, no other form of wireless communications shall be used to communicate to, from, or within the OPERATOR CONSOLE.

Examples of prohibited wireless systems include, but are not limited to, active wireless network cards and Bluetooth devices. For the case of the *FIRST* Robotics Competition, a motion sensing input device (e.g. Microsoft Kinect) is not considered wireless communication and is allowed.





R101. OPERATOR CONSOLES shall not be made using hazardous materials, be unsafe, cause an unsafe condition, or interfere with other DRIVE TEAMS or the operation of other ROBOTS.





9 Inspection & Eligibility Rules

This section describes the rules governing MATCH participation. A Team has participated in a MATCH if any member of their DRIVE TEAM is in the ALLIANCE STATION, with or without the ROBOT on the FIELD, at the start of the MATCH.

At each event, the Lead Robot Inspector (LRI) has final authority on the legality of any COMPONENT, MECHANISM, or ROBOT. Inspectors may re-Inspect ROBOTS to ensure compliance with the rules.

ROBOTS are permitted to participate in scheduled Practice MATCHES prior to passing Inspection. However, the *FIRST* Technical Advisor (FTA), LRI, or Head REFEREE may determine at any time that the ROBOT is unsafe, per safety rules, and may prohibit further participation in Practice MATCHES until the condition is corrected and/or the ROBOT passes Inspection.

Prior to the start of a MATCH, any ROBOT which is unable or ineligible to participate in that MATCH as determined by the FTA, LRI, or Head REFEREE is declared to be BYPASSED and is DISABLED. A Team whose ROBOT is BYPASSED remains eligible to receive Qualification Ranking Points or Playoff MATCH points provided that its ROBOT has passed Inspection, per I02.

- I01. The ROBOT must be built by the Team and to play this year's game.** The ROBOT is an electromechanical assembly built by the *FIRST*[®] Robotics Competition Team to perform specific tasks when competing in *FIRST*[®] STEAMWORKSSM. The ROBOT must include all of the basic systems required to be an active participant in the game – power, communications, control, BUMPERS, and movement. The ROBOT implementation must obviously follow a design approach intended to play *FIRST* STEAMWORKS (e.g. a box of unassembled parts placed on the FIELD, or a ROBOT designed to play a different game does not satisfy this definition).

I01 requires that the ROBOT a Team uses in competition was built by that Team, but isn't intended to prohibit assistance from other Teams (e.g. fabricating elements, supporting construction, writing software, developing game strategy, contributing COMPONENTS and/or MECHANISMS, etc.).

- I02. Get inspected before playing a Qualification/Playoff MATCH.** A Team is only permitted to participate in a Qualification or Playoff MATCH and receive Ranking or MATCH Points respectively if their ROBOT has passed an initial, complete Inspection.

Violation: If prior to the start of the MATCH, the Team is not eligible to participate in the MATCH. If after the start of the MATCH, the entire ALLIANCE receives a RED CARD for that MATCH.

Please take note of this rule. It is important that *FIRST* Robotics Competition Teams ensure their ALLIANCE partners have passed Inspection. Allowing a partner that has not passed Inspection to play puts the ALLIANCE at risk of RED CARDS. Teams should check with their ALLIANCE partners early, and help them pass Inspection before competing.

- I03. Bring it all to Inspection.** At the time of Inspection, the ROBOT must be presented with all MECHANISMS (including all COMPONENTS of each MECHANISM), configurations, and decorations that will be used on the ROBOT during the competition event. It is acceptable, however, for a ROBOT to play MATCHES with a subset of the MECHANISMS that were present during Inspection. Only MECHANISMS that were present during the Inspection may be added,





removed or reconfigured between MATCHES. If MECHANISMS are changed between MATCHES, the reconfigured ROBOT must still meet all Inspection criteria.

104. ROPES have to be inspected. A Team must submit any ROPE they intend to use in a MATCH for Inspection. A ROPE must meet the following criteria (see Figure 9-2 for letter references):

- A. have a maximum width (W) of 1 in. (nominal) (e.g. exclusive of any knot widths)
- B. be designed/configured to be at least 5 ft. 3 in. (~160 cm) long measured from the side of the ROPE'S retaining feature (per I04-E) that abuts the DAVIT fingers (L), to the farthest point on the ROPE from this feature.
- C. be designed/configured to not exceed a length of 8 ft. (~244 cm) measured from the side of the ROPE'S retaining feature (per I04-E) that abuts the DAVIT fingers (L), to the farthest point on the ROPE from this feature.
- D. consist entirely of flexible, non-metallic fibers twisted, tied, woven, or braided together except for the last 4 in. (~10 cm) of any cut end (E) which may be whipped (with material that is flexible and non-metallic) or fused only to prevent fraying.

Flexible means that if the ROPE is held at any point, it should not extend more than 12 in. (~30 cm) above the point where it is held. ROPES are meant to be pulled, not pushed.

Figure 9-1 ROPE examples



- E. be configured such that it engages securely with the FIELD.

To interface with the field a ROPE must have a retaining feature (e.g. a knot) greater than 1 in. (~25.4 mm) in diameter to interface with the DAVITS (RF).

- F. if knotted, the top knot must be at least 29 in. (~74 cm) below the retaining knot/feature (K)
- G. if knotted or looped, the total diameter does not exceed 10 in. (~25 cm) (D)



If the ROPE has a loose loop such that, uncompressed it's 12 in. (~30 cm) in diameter, but it can be easily compressed by hand to less than 10 in., that ROPE has met the requirement of part I04-G.

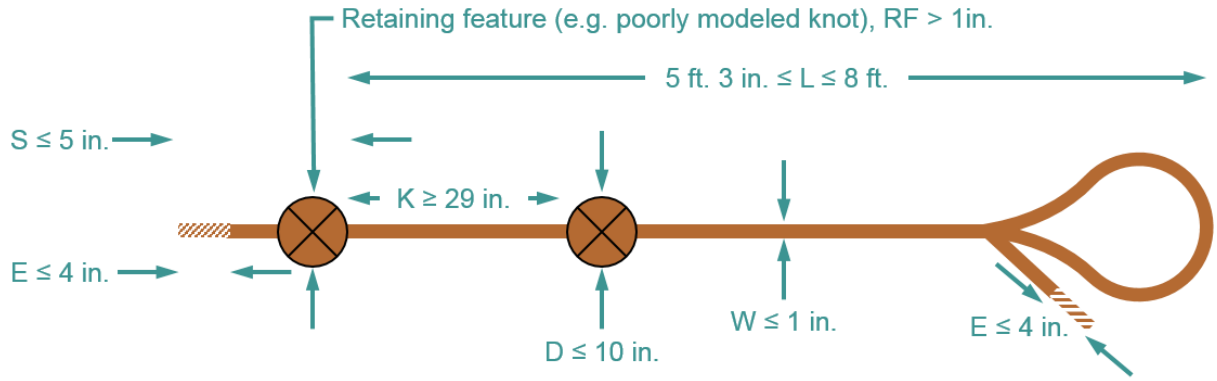
- H. be designed/configured to not exceed a length of 5 in. (~12 cm) measured from the side of the ROPE'S retaining feature (per I04-E) that abuts the DAVIT fingers, to the closest end on the ROPE from this feature (S).

The intent of I04 is to allow Teams the convenience of bringing their own ROPE for reliability and predictability purposes, as well as accommodate some modifications to ease the challenge associated with accessing the TOUCHPAD (e.g. tying knots).

The modifications allowed are limited, however. For example, consider the limitation of the purpose of whipping or fusing to prevent fraying in I04-D and that *FIRST* Robotics Community members are innovative and may discover a way to fuse the end of the ROPE in a way that can be leveraged for competitive advantage. This "superfusion" extends the fusing's purpose beyond only preventing fraying.

We acknowledge that this could result in temptation to implement the superfusion method anyway and hope an Inspector doesn't notice, or that you will be able to convince them the superfusion method really is "only to prevent fraying." Please don't do this. It will likely lead to a bad experience both for you and the volunteer who really does want you to participate in the event, but with a 100% legal ROBOT.

Figure 9-2 ROPE anatomy



- 105. Unless the change is listed below, any change to a ROBOT must get re-inspected.** If a ROBOT is modified after it has passed its most recent Inspection, that ROBOT must be re-Inspected before the ROBOT is eligible to participate in a MATCH. Exceptions are listed in A through F (unless they result in a significant change to the ROBOT'S size, weight, legality, or safety).
- A. addition, relocation, or removal of fasteners (e.g. cable ties, tape, and rivets)
 - B. addition, relocation, or removal of labeling or marking
 - C. revision of ROBOT code
 - D. replacement of a COTS COMPONENT with an identical COTS COMPONENT



- E. replacement of a MECHANISM with an identical MECHANISM (size, weight, material)
- F. additions, removals, or reconfiguration of ROBOT with a subset of MECHANISMS already inspected per I02.

When in doubt, the Team should ask to be re-Inspected.

Inspectors prioritize ROBOTS that have not yet completed initial inspection over ROBOT changes and ROPES.

While every effort will be made to re-inspect Teams in a timely manner, Teams need to consider that they may need to play with the previously inspected configuration if re-inspection cannot be completed before a MATCH. Teams should work with Inspectors when making changes to minimize the chance of this occurring.

Example 1: Team A's ROBOT has passed Inspection, but burns out a motor controller during a MATCH. Team A replaces it with an identical motor controller. Team A does not have to get their ROBOT re-Inspected per exception I05-D.

Example 2: Team B would like to add weight to their ROBOT to lower their center of gravity. Team B adds a large amount of fasteners to their ROBOT as ballast. Team B must get their ROBOT re-Inspected because they have significantly changed their weight per I05.

Example 3: Team D has decided to move their motor controller to a different location on their ROBOT, and must use a different length wire to make the proper connections. Team D must get their ROBOT re-Inspected because rewiring is not an exception in I05.

Example 4: Team E decides to relocate their battery on their ROBOT to change their center of gravity. Team E must be re-Inspected as the relocation of COMPONENTS or MECHANISMS is not an exception I05.

Example 5: Team F realizes they can gain necessary functionality by building a new MECHANISM at an event and adding it to their ROBOT. Their ROBOT must be re-Inspected.

If an observation is made that another Team's ROBOT may be in violation of the ROBOT rules, please approach *FIRST* officials to review the matter in question. This is an area where Gracious Professionalism® is very important.

- 106. Changes to a ROPE need re-inspection.** If a ROPE is modified after it has passed its most recent Inspection, that ROPE must be re-Inspected before the ROPE is eligible for a MATCH.
- 107. Document your costs.** A Cost Accounting Worksheet (CAW), listing all items on the ROBOT except those listed in R10 and their relevant costs per [Section 8.4 Budget Constraints & Fabrication Schedule](#), must be presented at the time of Inspection.

Teams are encouraged to use the [CAW Template](#) posted on the *FIRST* website. Please note that while CAWs must be shown to Inspectors, Teams are not required to submit their CAWs to the Inspectors.



108. ROBOTS are off for Inspection, mostly. For the safety of all those involved, Inspections must take place with the ROBOT powered off, pneumatics unpressurized, and springs or other stored energy devices in their lowest potential energy states (e.g. battery removed).

Power and air pressure should only be enabled on the ROBOT during those portions of the Inspection process where it is absolutely required to validate certain system functionality and compliance with specific rules (firmware check, etc.). Inspectors may allow the ROBOT to be powered up beyond the parameters above if both criteria below are met.

- A. The ROBOT design requires power or a charged stored energy device in order to confirm that the ROBOT meets volume requirements, and
- B. The Team has included safety interlocks that mitigate unexpected release of such stored energy.

The Team may be asked to demonstrate these interlocks during the inspection process.

109. No student, no Inspection. At least one student Team member must accompany the ROBOT for any Inspection efforts.

Exceptions may be made for major conflicts, e.g. religious holidays, major testing, transportation issues, etc.





10 Tournaments

Each 2017 *FIRST* Robotics Competition event is played in a tournament format. Each tournament consists of three sets of MATCHES called Practice MATCHES (not necessarily at all District Events), Qualification MATCHES, and Playoff MATCHES.

Practice MATCHES provide each Team with an opportunity to operate its ROBOT on the FIELD prior to the start of the Qualification MATCHES.

Qualification MATCHES allow each Team to earn a seeding position that may qualify them for participation in the Playoff MATCHES.

Playoff MATCHES determine the event Champions.

10.1 MATCH Schedules

A MATCH schedule is used to coordinate MATCHES at an Event. Figure 10-1 details information shown on each Schedule.

Figure 10-1: Sample MATCH Schedule

Qualification Match Schedule

Event Name								
Matches Per Team		10	ALLIANCE Red or Blue					
Time	Description	Match	Blue 1	Blue 2	Blue 3	Red 1	Red 2	Red 3
Thu 2:30	Qualification 1 (A)	1	1	2	3	4	5	6
Thu 2:37	Qualification 2 (A)	2	7	8	9	10	11*	12
Thu 2:44	Qualification 3 (A)	3	13	14	15*	16	17	18

PLAYER STATION number 1, 2, or 3

MATCH Start Time MATCH Type MATCH Number SURROGATE MATCH indicator

10.2 Practice MATCHES

Practice MATCHES are played on the first day of each event. The Practice MATCH schedule is available as soon as possible, but no later than the start of Practice MATCHES. Practice MATCHES are randomly assigned, and teams may not switch scheduled Practice MATCHES. Each Team is assigned an equal number of Practice MATCHES unless the number of Teams multiplied by number of Practice MATCHES is not divisible by six. In this case, the FIELD Management System (FMS) randomly selects some Teams to play an extra Practice MATCH.

Practice MATCHES are not guaranteed at District Events.

10.2.1 Filler Line

A Filler Line is used to fill open slots at events that employ scheduled Practice MATCHES, or all slots at events with an open Practice MATCH schedule. Teams from the Filler Line are used on a first come, first served basis to fill empty spots in Practice MATCHES left by other Teams that do not report to Queueing. The number of Teams in the Filler Line is dependent upon space at venues





- T01.** Teams wanting additional Practice MATCHES may not join the Filler Line unless all criteria listed below are met:
- A.** ROBOTS in the Filler Line must have passed Inspection (this requirement may be waived for events with open Practice MATCH schedules);
 - B.** DRIVE TEAMS must join the Filler Line with their ROBOT;
 - C.** Teams may not work on their ROBOT while in the Filler Line;
 - D.** Teams may not occupy more than one spot in the Filler Line; and
 - E.** If a Team is queued for their Practice MATCH, they may not also join the Filler Line.

10.3 Measurement

The ARENA will be open for at least thirty (30) minutes prior to the start of Qualification MATCHES, during which time Teams may survey and/or measure the FIELD and bring ROBOTS on the FIELD to perform sensor calibration. The specific time that the FIELD is open will be communicated to Teams at the event. Teams may bring specific questions or comments to the FTA.

- T02.** During the period when the ARENA is open for measurement, ROBOTS can be enabled, but cannot move, nor can they interact (e.g. shoot, push, pickup, etc.) with GAME PIECES or the AIRSHIP.

Violation: YELLOW CARD.

10.4 Qualification MATCHES

10.4.1 Schedule

The Qualification MATCH schedule is made available as soon as possible, but no later than one (1) hour before Qualification MATCHES are scheduled to begin. Each Qualification schedule consists of a series of rounds in which each team plays one (1) MATCH per round.

10.4.2 MATCH Assignment

FMS assigns each Team two (2) ALLIANCE partners for each Qualification MATCH using a predefined algorithm, and teams may not switch Qualification MATCH assignments. The algorithm employs the following criteria, listed in order of priority:

1. Maximize time between each MATCH played for all Teams
2. Minimize the number of times a Team plays opposite any Team
3. Minimize the number of times a Team is allied with any Team
4. Minimize the use of SURROGATES (Teams randomly assigned by the FMS to play an extra Qualification MATCH)
5. Provide even distribution of MATCHES played on Blue and Red ALLIANCE

All Teams are assigned the same number of Qualification MATCHES, equal to the number of rounds, unless the number of Teams multiplied by number of MATCHES is not divisible by six. In this case, the FMS randomly selects some Teams to play an extra MATCH. For the purpose of seeding calculations, those Teams are designated as SURROGATES for the extra MATCH. If a Team plays a MATCH as a SURROGATE, it is indicated on the MATCH schedule, it is always their third Qualification MATCH, and the outcome of the MATCH has no effect on the Team's ranking. YELLOW and RED CARDS assigned to SURROGATES do carry forward to subsequent MATCHES.





10.4.3 Qualification Ranking

Ranking Points (RP) are units credited to a Team based on their ALLIANCE'S performance in Qualification MATCHES. Ranking Points are awarded to each eligible Team at the completion of each Qualification MATCH:

- A. Each Team on the winning ALLIANCE receives two (2) Ranking Points.
- B. Each Team on the losing ALLIANCE receives zero (0) Ranking Points.
- C. In the event of a tied score, all Teams receive one (1) Ranking Point.
- D. Each Team on an ALLIANCE that achieves at least 40 kPa receives one (1) Ranking Point.
- E. Each Team on an ALLIANCE that engages all four (4) ROTORS by the end of the MATCH receives one (1) Ranking Point.

Exceptions to A-E are as follows:

- A. A SURROGATE receives zero (0) Ranking Points.
- B. A DISQUALIFIED Team, as determined by the Head REFEREE, receives zero (0) Ranking Points in a Qualification MATCH or causes their ALLIANCE to receive zero (0) MATCH points in a Playoff MATCH.
- C. A "no-show" Team is DISQUALIFIED from that MATCH. A Team is declared a no-show if no member of the DRIVE TEAM is in the ALLIANCE STATION, AIRSHIP, or LOADING LANE at the start of the MATCH.

The total number of Ranking Points earned by a Team throughout their Qualification MATCHES divided by the number of MATCHES they've been scheduled to play (minus any SURROGATE MATCH) is their Ranking Score (RS).

All Teams participating in Qualification MATCHES are ranked by Ranking Score. If the number of Teams in attendance is 'n', they are ranked '1' through 'n', with '1' being the highest ranked Team and 'n' being the lowest ranked Team.

Teams are ranked in order, using the sorting criteria defined in Table 10-1.

Table 10-1: Qualification MATCH Ranking Criteria

Order Sort	Criteria
1 st	Ranking Score
2 nd	Cumulative sum of MATCH points
3 rd	Cumulative sum of AUTO points
4 th	Cumulative ROTOR engagement score (AUTO and TELEOP)
5 th	Cumulative TOUCHPAD score
6 th	Total accumulated pressure
7 th	Random sorting by the FMS

10.5 Playoff MATCHES

In Playoff MATCHES, Teams do not earn Ranking Points; they earn a Win, Loss or Tie. Within each series of the Playoff MATCH bracket, the first ALLIANCE to win two (2) MATCHES will advance.





In the case where the Quarterfinal or Semifinal MATCH scores for both ALLIANCES are equal, the Win is awarded to the ALLIANCE per criteria listed in Table 10-2. A DISQUALIFIED Team, as determined by the Head REFEREE, causes their ALLIANCE to receive zero (0) MATCH points in a Playoff MATCH.

In Finals MATCHES, the Champion ALLIANCE is the first ALLIANCE to win two (2) MATCHES. In the case where an ALLIANCE hasn't won two (2) MATCHES after three (3) MATCHES, the Playoffs proceed with up to three (3) additional Finals MATCHES, called Overtime MATCHES, until an ALLIANCE has won two (2) Finals MATCHES. In the case where the Overtime MATCH scores for both ALLIANCES are equal, the win for that Overtime MATCH is awarded based on the criteria listed in Table 10-2.

Table 10-2: Quarterfinal, Semifinal, and Overtime Tiebreaker Criteria

Order Sort	Criteria
1 st	Fewer FOUL points
2 nd	Cumulative sum of AUTO points
3 rd	Cumulative ROTOR engagement score (AUTO and TELEOP)
4 th	Cumulative TOUCHPAD score
5 th	Total accumulated pressure
6 th	MATCH is replayed

10.5.1 ALLIANCE Selection Process

At the end of the Qualification MATCHES, the top eight (8) seeded Teams become the ALLIANCE Leads. The seeded ALLIANCES are designated, in order, ALLIANCE One, ALLIANCE Two, etc., down to ALLIANCE Eight. Using the ALLIANCE selection process described in this section, each ALLIANCE Lead chooses two (2) other Teams to join their ALLIANCE.

If a Team declines the ALLIANCE Lead position or doesn't send a student representative for ALLIANCE selection, they are ineligible to participate in the Playoff Tournament. If the declining/absent Team would have been an ALLIANCE Lead, all lower ranked ALLIANCE Leads are promoted one spot. The next highest-ranked Team moves up to become the ALLIANCE Eight Lead.

Each Team chooses a student Team representative who proceeds to the ARENA at the designated time (typically before the lunch break on the final day of the event) to represent their Team. The designated student representative from each ALLIANCE in a Playoff MATCH is called the ALLIANCE CAPTAIN.

The ALLIANCE selection process consists of two (2) rounds during which each ALLIANCE CAPTAIN invites a Team seeded below them in the standings to join their ALLIANCE. The invited Team must not already have declined an invitation.

Round 1: In descending order (ALLIANCE One to ALLIANCE Eight), each ALLIANCE CAPTAIN invites a single Team. The invited Team's representative steps forward and either accepts or declines the invitation.

If the Team accepts, it becomes a member of that ALLIANCE. If an invitation from a top eight ALLIANCE to another ALLIANCE Lead is accepted, all lower ALLIANCE Leads are promoted one spot. The next highest-seeded, unselected Team moves up to become the ALLIANCE Eight Lead.

If the Team declines, that Team is not eligible to be picked again or to be a BACKUP TEAM (see [Section 10.5.2 BACKUP TEAMS](#)), and the ALLIANCE CAPTAIN extends another invitation to a different Team. If an invitation from a top eight ALLIANCE to another ALLIANCE Lead is declined, the declining Team may still invite Teams to join their ALLIANCE; however, it cannot accept invitations from other ALLIANCES.

The process continues until ALLIANCE Eight makes a successful invitation.





Round 2: The same method is used for each ALLIANCE CAPTAIN'S second choice except the selection order is reversed, with ALLIANCE Eight picking first and ALLIANCE One picking last. This process results in eight (8) ALLIANCES of three (3) Teams each.

Of the remaining eligible Teams, the highest seeded Teams must either accept or decline to be included in a pool of available Teams until there are up to eight (8) Teams that accept to be added into the pool. FIELD STAFF will coordinate the assembly of this BACKUP pool immediately after the top ranked ALLIANCE has made their final pick. If a Team is not available to accept inclusion in the BACKUP pool, it will be assumed they have declined the invitation.

10.5.2 BACKUP TEAMS

In the Playoff MATCHES, it may be necessary for an ALLIANCE to replace one of its members due to a faulty ROBOT. ROBOT faults include but are not limited to:

1. mechanical damage,
2. electrical issues, or
3. software problems.

In this situation, the ALLIANCE CAPTAIN has the option to bring in only the highest seeded Team from the pool of available Teams to join its ALLIANCE. The Team whose ROBOT and DRIVE TEAM replaces another ROBOT and DRIVE TEAM on an ALLIANCE during the Playoff MATCHES is called the BACKUP TEAM.

The resulting ALLIANCE is then composed of four (4) Teams. The replaced Team remains a member of the ALLIANCE for awards, but cannot return to play, even if their ROBOT is repaired.

Each ALLIANCE is allotted one (1) BACKUP TEAM Coupon during the Playoff MATCHES. If a second ROBOT from the ALLIANCE becomes inoperable, then the ALLIANCE must play the following MATCHES with only two (2) (or even one (1)) ROBOTS.

Example: Three (3) Teams, A, B and C, form an ALLIANCE going into the Playoff MATCHES. The highest seeded Team not on one of the eight (8) ALLIANCES is Team D. During one of the Playoff MATCHES, Team C's ROBOT suffers damage to its mechanical arm. The ALLIANCE CAPTAIN decides to bring in Team D to replace Team C. Team C and their ROBOT are not eligible to play in any subsequent Playoff MATCHES. The new ALLIANCE of Teams A, B, and D are successful in advancing to the Finals and win the event. Teams A, B, C, and D are all recognized as members of the Winning ALLIANCE and receive awards

In the case where a BACKUP TEAM is part of the Winning or Finalist ALLIANCE, there will be a four (4)-Team Winning or Finalist ALLIANCE.

10.5.3 Playoff MATCH Bracket

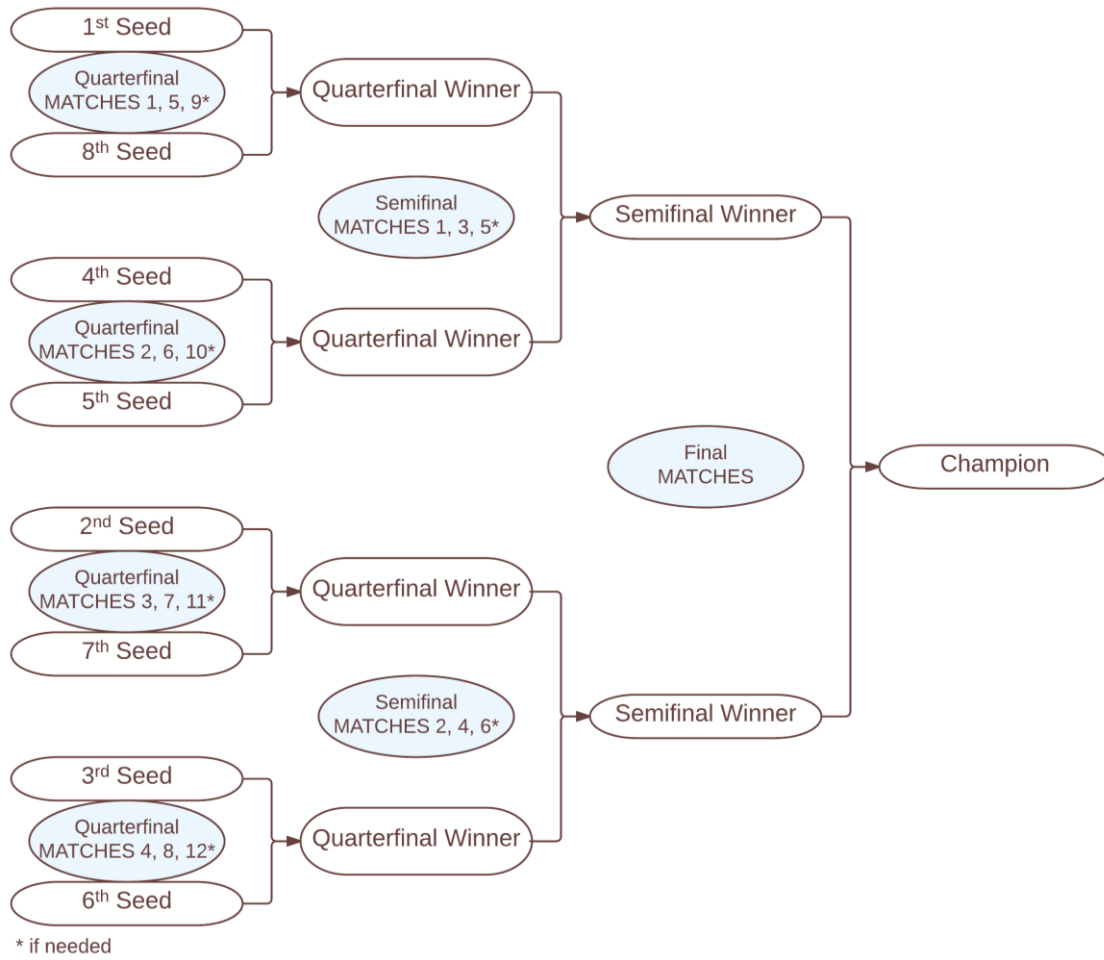
The Playoff MATCHES take place following the completion of the Qualification MATCHES and the ALLIANCE selection process. Playoff MATCHES are played in a bracket format as shown in Figure 10-2.

ALLIANCE Leads are assigned to PLAYER STATION 2, the first picks are assigned to PLAYER STATION 1, and second picks are assigned to PLAYER STATION 3. If a BACKUP TEAM is in play, they will be assigned to the PLAYER STATION that was assigned to the DRIVE TEAM they're replacing.





Figure 10-2: Playoff MATCH Bracket





In order to allow time between MATCHES for all ALLIANCES, the order of play is as follows:

Table 10-3: Playoff Order

Quarterfinal Round 1	Quarterfinal Round 2	Quarterfinal Round 3	Semifinals	Finals
Quarterfinal 1 (1 vs.8)	Quarterfinal 5 (1 vs.8)	Quarterfinal Tiebreaker 1 ¹	Semifinal 1	Final 1
Quarterfinal 2 (4 vs.5)	Quarterfinal 6 (4 vs.5)	Quarterfinal Tiebreaker 2 ¹	Semifinal 2	FIELD TIMEOUT
Quarterfinal 3 (2 vs.7)	Quarterfinal 7 (2 vs.7)	Quarterfinal Tiebreaker 3 ¹	Semifinal 3	Final 2
Quarterfinal 4 (3 vs.6)	Quarterfinal 8 (3 vs.6)	Quarterfinal Tiebreaker 4 ¹	Semifinal 4	FIELD TIMEOUT
FIELD TIMEOUT ¹	FIELD TIMEOUT ¹	FIELD TIMEOUT ¹	Semifinal Tiebreaker 1 ¹	Final Tiebreakers (Overtime) ¹
		Any Replays due to ties ¹	Semifinal Tiebreaker 2 ¹	
			FIELD TIMEOUT ¹	Any Replays due to ties ¹
			Any Replays due to ties ¹	

¹ - if required

10.6 REFEREE Interaction

The Head REFEREE has the ultimate authority in the ARENA during the event, but may receive input from additional sources, e.g. Game Designers, *FIRST* personnel, FTA, and technical staff. The Head REFEREE rulings are final. No event personnel, including the Head REFEREE, will review video, photos, artistic renderings, etc. of any MATCH, from any source, under any circumstances.

If a DRIVE TEAM needs clarification on a ruling or score, per C09, one (1) pre-college student from that DRIVE TEAM should address the Head REFEREE after the ARENA Reset Signal (e.g. LED lights turn green). A DRIVE TEAM member signals their desire to speak with the Head REFEREE by standing in the corresponding Red or Blue Question Box, which are located on the floor near each end of the scoring table. Depending on timing, the Head REFEREE may postpone any requested discussion until the end of the subsequent MATCH.

While FMS tracks quantities of FOULS and TECH FOULS, *FIRST* instructs REFEREES to not self-track details about FOULS and TECHNICAL FOULS; as a result, we don't expect REFEREES to recall details about what FOULS or TECHNICAL FOULS were made, when they occurred, and against whom.





Any reasonable question is fair game in the Question Box, and Head REFEREES will do good faith efforts to provide helpful feedback (e.g. how/why certain FOULS are being called, why a particular ROBOT may be susceptible to certain FOULS based on its design or game play, how specific rules are being called or interpreted), but please know that they will likely not be able to supply specific details

10.7 YELLOW and RED CARDS

In addition to rule violations explicitly listed throughout the **2017 Game and Season Manual**, YELLOW CARDS and RED CARDS are used in *FIRST*® Robotics Competition to address Team and ROBOT behavior that does not align with the mission of *FIRST*®.

As noted in [Section 4.4 Rule Violations](#) and C01, the Head REFEREE may assign a YELLOW CARD as a warning, or a RED CARD for DISQUALIFICATION in MATCH for egregious behavior inappropriate at a *FIRST* Robotics Competition event.

T03. Egregious or repeated violations of any rule or procedure is prohibited.

Violation: The Head REFEREE may assign a YELLOW CARD as a warning, or a RED CARD for DISQUALIFICATION in MATCH.

A YELLOW or RED CARD is indicated by the Head REFEREE standing in front of the Team's PLAYER STATION and holding a YELLOW and/or RED CARD in the air.

YELLOW CARDS are additive, meaning that a second YELLOW CARD is automatically converted to a RED CARD. A Team is issued a RED CARD for any subsequent incident in which they receive an additional YELLOW CARD, including earning a second YELLOW CARD during a single MATCH. A second YELLOW CARD is indicated by the Head REFEREE standing in front of the Team's PLAYER STATION and holding a YELLOW CARD and RED CARD in the air simultaneously after the completion of the MATCH. A Team that has received either a YELLOW CARD or a RED CARD carries a YELLOW CARD into subsequent MATCHES, except as noted below. A RED CARD results in DISQUALIFICATION.

Once a Team receives a YELLOW or RED CARD, its Team number will be presented with a yellow background on the audience screen at the beginning of all subsequent MATCHES, including any replays, as a reminder to the Team, the REFEREES, and the audience that they carry a YELLOW CARD.

Figure 10-3: Audience Screen Graphic Showing YELLOW and RED CARD Indicators

Image coming soon!

All YELLOW CARDS are cleared at the conclusion of Qualification MATCHES, providing teams a clean slate at the beginning of Playoff MATCHES.

During the Playoff MATCHES, if a Team receives a YELLOW or RED CARD, it results in the entire ALLIANCE receiving the YELLOW or RED CARD for that MATCH. If two different Teams on the same ALLIANCE are issued YELLOW CARDS, the entire ALLIANCE is issued a RED CARD. A RED CARD results in zero (0) points for that MATCH, and the ALLIANCE loses the MATCH. If both ALLIANCES receive RED CARDS, the ALLIANCE which committed the action earning the RED CARD first chronologically loses the MATCH.





YELLOW and RED CARDS are applied based on the following:

Table 10-4: YELLOW and RED CARD application

Time YELLOW or RED CARD earned:	MATCH to which CARD is applied:
prior to the start of Qualification MATCHES	Team's first Qualification MATCH
during the Qualification MATCHES	Team's current (or just-completed) MATCH. In the case where the Team participated as a SURROGATE in the current (or just completed) MATCH, the card is applied to the Team's previous MATCH (i.e. the Team's second Qualification MATCH.)
between the end of Qualification MATCHES and the start of Playoff MATCHES	ALLIANCE'S first Playoff MATCH

10.8 MATCH Replays

Over the course of the Tournament, ARENA FAULTS may occur. An ARENA FAULT is an error in ARENA operation that includes, but is not limited to:

- A. broken FIELD elements
- B. power failure to a portion of the FIELD (tripping the circuit breaker in the PLAYER STATION is not considered a power failure)
- C. improper activation by the FMS
- D. errors by FIELD STAFF
- E. a Team BANNER falling into the FIELD

If, in the judgment of the Head REFEREE, an ARENA FAULT occurs that affects the outcome of the MATCH and any team on the affected ALLIANCE desires a replay, the MATCH will be replayed.

All reasonable effort is made to create the same conditions when replaying a MATCH. This means, for example, that a Team which was BYPASSED during the MATCH which is to be replayed, is BYPASSED for the replay MATCH.

Note that an ARENA FAULT that does not affect MATCH outcome in the judgement of the Head REFEREE does not lead to a MATCH replay. Examples include, but are not limited to:

- A. a piece of FIELD plastic falls into the FIELD in the last 5 seconds of a MATCH, far away from any human or ROBOT activity, and in such a way that it does not affect MATCH outcome
- B. delay in the playing of an ARENA sound
- C. mismatch between the timer on the Audience Screen and the FIELD Timer
- D. any adjustment or delay in assignment of a penalty (including those made after the MATCH)

10.9 TIMEOUTS and BACKUP TEAMS

A TIMEOUT is a period of up to six (6) minutes between MATCHES which is used to pause Playoff MATCH progression.



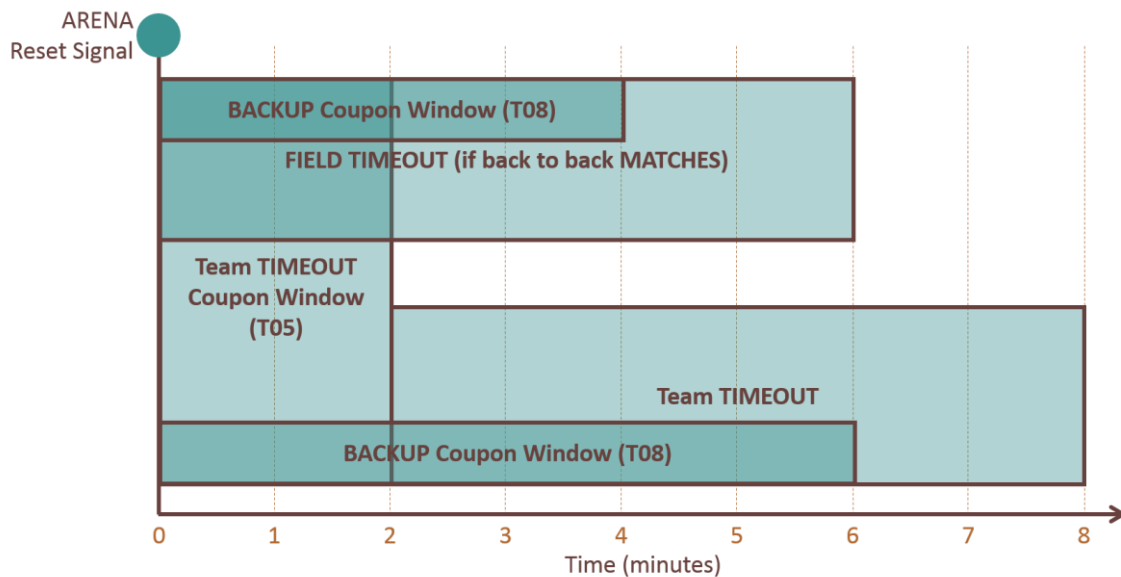


During a TIMEOUT, the ARENA Timer will display the time remaining in the TIMEOUT. Both ALLIANCES will enjoy the complete six (6) minute window. If an ALLIANCE completes their repairs before the ARENA Timer expires, the ALLIANCE CAPTAIN is encouraged to inform the Head REFEREE that they are ready to play. If both ALLIANCES are ready to play before the TIMEOUT expires, the next MATCH will start.

There are no TIMEOUTS in the Practice or Qualification MATCHES.

If circumstances require an ALLIANCE to play in back-to-back MATCHES during the Playoff MATCHES, the Head REFEREE will issue a FIELD TIMEOUT to allow Teams to prepare for the next MATCH. FIELD TIMEOUTS are the same time duration as TIMEOUTS.

Figure 10-4: TIMEOUT Timeline



T04. An ALLIANCE may not call more than one (1) TIMEOUT during the Playoff MATCHES.

Teams are expected to have their ROBOTS staged on the FIELD by the end of the TIMEOUT. Teams that cause a significant delay to the start of a MATCH after a TIMEOUT are subject to G02.

T05. If an ALLIANCE wishes to call a TIMEOUT, the ALLIANCE CAPTAIN must submit their TIMEOUT coupon to the Head REFEREE within two (2) minutes of the ARENA reset signal preceding their MATCH. If there is no preceding MATCH, the TIMEOUT coupon must be submitted no later than two (2) minutes before the scheduled MATCH time. The TIMEOUT will begin two (2) minutes after the ARENA reset signal (i.e. at the end of the TEAM TIMEOUT Coupon Window depicted in Figure 10-4)

T06. There are no cascading TIMEOUTS. If an ALLIANCE calls a TIMEOUT during a FIELD TIMEOUT, the FIELD TIMEOUT will expire two (2) minutes after the ARENA reset signal and the ALLIANCE'S TIMEOUT will begin.

If an ALLIANCE wishes to call a TIMEOUT during a FIELD TIMEOUT, it must still do so within two (2) minutes of the ARENA reset signal preceding their MATCH, per T05.





T07. TIMEOUTS are not transferrable between ALLIANCES.

While TIMEOUTS are not transferrable between ALLIANCES, meaning an ALLIANCE cannot hand their designated TIMEOUT coupon to another ALLIANCE to use, an ALLIANCE may use their own coupon for any purpose they wish.

T08. If during a TIMEOUT an ALLIANCE CAPTAIN determines that they need to call up a BACKUP TEAM, they must submit their BACKUP TEAM coupon to the Head REFEREE while there are still at least two (2) minutes remaining on the ARENA Timer. After that point, they will not be allowed to utilize the BACKUP TEAM.

Alternatively, an ALLIANCE CAPTAIN may choose to call up a BACKUP TEAM without using their TIMEOUT by informing the Head REFEREE directly within two (2) minutes of the Head REFEREE issuing the ARENA reset signal preceding their MATCH. If there is no preceding MATCH, the BACKUP TEAM coupon must be submitted no later than two (2) minutes before the scheduled MATCH time.

In the case where the ALLIANCE CAPTAIN'S ROBOT is replaced by a BACKUP TEAM, the ALLIANCE CAPTAIN is allowed as a sixteenth ALLIANCE member.

The Head REFEREE will not accept the BACKUP TEAM coupon unless it lists the number of the Team whose ROBOT is being replaced, and is initialed by the ALLIANCE CAPTAIN. Once a BACKUP TEAM coupon is submitted and accepted by the Head REFEREE, the BACKUP TEAM coupon may not be withdrawn by the ALLIANCE.

T09. An ALLIANCE may request neither a TIMEOUT nor a BACKUP TEAM after a Playoff MATCH is stopped by the Head REFEREE (e.g. due to an ARENA FAULT or a safety issue). The sole exception is if the replay is due to an ARENA FAULT that rendered a ROBOT inoperable.

If a Playoff MATCH is replayed per T09, the Head REFEREE has the option of calling a FIELD TIMEOUT.

10.10 Pit Crews

During the Playoff MATCHES, extra Team members may be needed to maintain the ROBOT between MATCHES because of the distance between the FIELD and the pit area. Each Team is permitted to have three (3) additional pit crew members who can also help with needed ROBOT repairs/maintenance

T10. Pit Crew members may not be in the ALLIANCE STATION during a MATCH.

Violation: MATCH will not start until the situation is corrected. Those not displaying identification must leave the ARENA.

10.11 FIRST® Championship Additions and Exceptions

At the 2017 FIRST Championship, Teams are split into six (6) Subdivisions. Each Subdivision plays a standard Tournament as described in [Section 10 Tournaments](#) to produce the Subdivision Champions. Those six (6) Subdivision Champions proceed to the Championship Playoffs, on the Einstein FIELD, to determine the 2017 FIRST® Robotics Competition Champions.

There is no provision for BACKUP TEAMS at the Championship.





10.II.1 Four ROBOT ALLIANCES

Before each Subdivision Playoff Tournament, ALLIANCES will be selected per the process as described in [Section 10.5.1 ALLIANCE Selection Process](#), however the process will continue with a 3rd round of selection as follows.

Round 3: The same method is used for each ALLIANCE CAPTAIN'S third choice except the selection order is reversed again, with ALLIANCE One picking first and ALLIANCE Eight picking last. This process results in eight (8) ALLIANCES of four (4) Teams each.

ALLIANCES may start with any three (3) of the four (4) ROBOTS on their ALLIANCE during Subdivision Playoff MATCHES and during the Championship Playoffs. The list of three (3) Teams participating in the MATCH and their selected PLAYER STATIONS is called the LINEUP. One representative from the Team not on the LINEUP is allowed as a sixteenth ALLIANCE member.

T11. The ALLIANCE CAPTAIN must report the LINEUP to the Head REFEREE, or their designee, in writing prior to end of the preceding MATCH (e.g. the LINEUPS for Quarterfinal 2 must be submitted before the end of Quarterfinal 1). If there is no preceding MATCH, the LINEUP is due no later than two (2) minutes before the scheduled MATCH time.

Violation: The LINEUP is the same as the ALLIANCE'S previous MATCH. If any of these three (3) ROBOTS are unable to play, the ALLIANCE must play the MATCH with only two (2) (or even one (1)) ROBOTS

If an ALLIANCE fails to submit a LINEUP per the process defined in T11 and the MATCH is their first of the Subdivision Playoffs or the Championship Playoffs, the LINEUP will be the ALLIANCE Lead, first ALLIANCE selection, and second ALLIANCE selection. If any of these three (3) ROBOTS are unable to play, the ALLIANCE must play the MATCH with only two (2) (or even one (1)) ROBOTS.

The LINEUP will be kept confidential until the FIELD is set for the MATCH, at which point each ALLIANCE'S LINEUP will appear on the Team Signs.

T12. Once the LINEUP has been declared, it cannot be changed unless there is a TIMEOUT. If there is a TIMEOUT, the ALLIANCE CAPTAIN may submit a different LINEUP, but must do so while there are still more than two (2) minutes remaining in the TIMEOUT.

Example: Four (4) Teams, A, B, C and D, form an ALLIANCE going into the Playoff MATCHES on their Subdivision FIELD. During one of the Playoff MATCHES, Team C's ROBOT becomes inoperable. The ALLIANCE decides to bring in Team D to replace Team C. Team C repairs their ROBOT and may play in any subsequent Playoff MATCHES replacing Teams A, B, or D. All four (4) ALLIANCE members are also eligible to play MATCHES during the Championship Playoffs should the ALLIANCE win the Subdivision Tournament.

T13. If a MATCH must be replayed due to an ARENA FAULT, the LINEUP for the replayed MATCH is the same as the original MATCH. The sole exception is if the ARENA FAULT rendered a ROBOT inoperable, in which case the LINEUP can be changed.

10.II.2 FIRST Championship Pit Crews

FIRST will distribute badges to the ALLIANCE CAPTAINS during the ALLIANCE CAPTAIN meeting, which takes place on the Subdivision FIELDS. These badges will provide the necessary access to the ARENA for pit crew members.





T14. Only Team members wearing proper badges are allowed on the ARENA floor during Subdivision and Championship Playoff MATCHES

Violation: MATCH will not start until the situation is corrected. Those not displaying identification must leave the ARENA.

Teams should assume they may be chosen for an ALLIANCE and think about the logistics of badge distribution and set a plan prior to the ALLIANCE selection process. It is each ALLIANCE CAPTAIN'S responsibility to get the Team's badges to the pit crew members.

10.II.3 *FIRST* Championship Playoffs

The six (6) Subdivision Champions play a round-robin style tournament to determine the 2017 *FIRST* Robotics Competition Champions. In this format, each Subdivision Champion plays one MATCH against each of the other Subdivision Champions. The order of MATCHES is shown in Table 10-5.

Table 10-5: Championship MATCH order

MATCH	Houston	St. Louis
Round 1		
1	Carver v Turing	Archimedes v. Tesla
2	Galileo v Roebing	Carson v. Darwin
3	Hopper v Newton	Curie v. Daly
Round 2		
4	Carver v Roebing	Archimedes v. Darwin
5	Turing v Newton	Tesla v Daly
6	Galileo v Hopper	Carson v Curie
Round 3		
7	Carver v Newton	Archimedes v. Daly
8	Roebing v Hopper	Darwin v Curie
9	Turing v Galileo	Tesla v. Carson
Round 4		
10	Carver v Hopper	Archimedes v. Curie
11	Newton v Galileo	Daly v. Carson
12	Roebing v Turing	Darwin v. Tesla
Round 5		
13	Carver v Galileo	Archimedes v Carson
14	Hopper v Turing	Curie v Tesla
15	Newton v Roebing	Daly v. Darwin

T15. In the Championship Playoffs, ALLIANCES do not earn Ranking Points; they earn Championship Points. Championship Points are units credited to an ALLIANCE based on their performance in each MATCH and are awarded at the completion of each Round Robin tournament MATCH.

- A.** The winning ALLIANCE receives two (2) Championship Points
- B.** The losing ALLIANCE receives zero (0) Championship Points
- C.** In the event of a tied score, each ALLIANCE receives one (1) Championship Point

Exceptions to A-C are as follows:

- D.** A DISQUALIFIED Team, as determined by the Head REFEREE, causes their ALLIANCE to receive zero (0) Championship points.





The total number of Championship Points earned by a Team throughout the round robin MATCHES divided by the number of round robin Matches in which they've been scheduled is their Championship Score (CS).

All Teams participating in round robin Matches are ranked by Championship Score. If the number of Teams in attendance is 'n', they are ranked '1' through 'n', with '1' being the highest ranked Team and 'n' being the lowest ranked Team.

In the case where Championship Scores of two or more alliances are equal, the tie is broken using the criteria in Table 10-6

Table 10-6: Einstein Tournament Ranking Criteria

Order Sort	Criteria
1 st	Cumulative sum of MATCH points
2 nd	Cumulative sum of ROTOR and pressure bonuses
3 rd	Cumulative sum of AUTO points
4 th	Cumulative ROTOR engagement score (AUTO and TELEOP)
5 th	Cumulative TOUCHPAD score
6 th	<ul style="list-style-type: none"> • If tie affects which ALLIANCES advance to Playoffs, a tiebreaker MATCH is played between the affected ALLIANCES. • If tie is between ALLIANCES advancing to Playoffs, FMS randomly seeds tied alliances to determine ALLIANCE color.

The two ALLIANCES with the highest Championship Scores at the conclusion of the round robin tournament advance to the Einstein Finals. In the Einstein Finals, ALLIANCES do not earn points, they earn a Win, Loss or Tie. The first ALLIANCE to win two (2) MATCHES is declared the 2017 *FIRST* Robotics Competition Champions.

T16. During the Einstein Finals, if the MATCH score of each ALLIANCE is equal, the MATCH is replayed.

10.11.4 *FIRST* Championship TIMEOUTS

For the Einstein Tournament, each ALLIANCE will be issued one TIMEOUT coupon for use as described in [Section 10.9 TIMEOUTS and BACKUP TEAMS](#).

T17. If an Einstein ALLIANCE wishes to call a TIMEOUT, the ALLIANCE CAPTAIN must submit their TIMEOUT coupon to the Head REFEREE (or their designee) within two (2) minutes of the ARENA reset signal from the previous MATCH. If there is no preceding MATCH, the TIMEOUT coupon must be submitted no later than two (2) minutes before the scheduled MATCH time. The TIMEOUT will begin two (2) minutes after the ARENA reset signal (i.e. at the end of the TEAM TIMEOUT Coupon Window depicted in Figure 10-4.

10.12 Advancement Between Tournaments

Teams advance through the season depending on the events at which they compete: Regional or District. This section details how teams advance from Regional events to the *FIRST* Championship, or from District qualifying events, to their District Championship, to the *FIRST* Championship.

T18. A team is considered to have already earned a *FIRST* Championship invitation prior to the District, Regional, or District Championship if they are:

- A. pre-qualified or





A *FIRST*® Robotics Competition Team listed in the [Championship Eligibility Criteria document](#) is pre-qualified for the *FIRST* Championship if the Team meets one of the following criteria:

- A. member of the *FIRST*® Hall of Fame
- B. an original and sustaining team since 1992
- C. a 2016 *FIRST* Championship winner
- D. a 2016 *FIRST* Championship Engineering Inspiration Award winner

B. met the criteria outlined in T19 at a prior event.

10.12.1 Regional Events

T19. A Team competing at a Regional Event qualifies for the *FIRST* Championship by meeting one of the following criteria:

- A. Winning a qualifying award:
 - i. Regional Chairman's Award
 - ii. Engineering Inspiration Award
 - iii. Rookie All-Star Award
- B. A member of the Winning ALLIANCE
- C. Earning a Wild Card

10.12.2 Wild Cards

Wild cards are used to qualify additional teams for the *FIRST* Championship from Regional events.

T20. All Regional events have a minimum of one (1) Wild Card slot. Additional Wild Cards are generated as follows:

- A. Any team competing at a Regional event that has already qualified for the *FIRST* Championship prior to the Regional, per T18, and earns an additional spot, per T19, generates one (1) Wild Card.
- B. Any team earning two (2) qualifying spots at a single Regional per T19 (e.g. by being on the Winning Alliance and earning the Chairman's Award) generates one (1) Wild Card.
- C. A team who has already earned a spot at *FIRST* Championship prior to their current Regional, per T18, and earns two qualifying spots, per T19, will generate two Wild Card slots.

Wild Card slots are distributed to the Finalist ALLIANCE, in the order of team selection per [Section 10.5.1 ALLIANCE Selection Process](#), until either all Wild Card slots generated at that event are distributed or the Finalist ALLIANCE is out of teams, whichever comes first.

T21. If a member of the Finalist ALLIANCE has already qualified for the *FIRST* Championship, per T18, they are skipped and the next member of the ALLIANCE is awarded the available Wild Card.

T22. Unused Wild Card slots will not be backfilled or replaced.

A Team may decline a Wild Card, but this does not pass the Wild Card slot down to the next available Team. The Wild Card goes unused.





T23. Teams selected from the *FIRST* Championship Waitlist to participate at the *FIRST* Championship do not generate Wild Cards.

10.12.3 District Events

District teams are ranked throughout the season based on the points they earn at their first two home District events they attend, as well as at their District Championship. Points are awarded to teams as follows:

Table 10-7: District point assignment

Category	Points
Qualification Round Performance	$QualificationPoints(R, N, \alpha) = \left\lceil InvERF\left(\frac{N - 2R + 2}{\alpha N}\right) \left(\frac{10}{InvERF\left(\frac{1}{\alpha}\right)}\right) + 12 \right\rceil$ <p>(For a typically sized District event, this will result in a minimum of four (4) points being awarded for Qualification round performance. For events of all sizes, a maximum of twenty-two (22) points will be awarded.)</p>
ALLIANCE CAPTAINS	Equal to 17 minus the ALLIANCE CAPTAIN number (e.g. 14 points for ALLIANCE #3 Captain)
Draft Order Acceptance	Equal to 17 minus the Draft Order Acceptance Number (e.g. 12 points for the Team that is 5 th to accept an invitation)
Playoff Advancement	Points awarded based on team participation in individual playoff rounds, and whether or not the ALLIANCE advances. See details below.
Judged Team Awards	<ul style="list-style-type: none"> • 10 points for Chairman's Award • 8 points each for Engineering Inspiration and Rookie All Star Awards • 5 points each for all other judged Team awards
Team Age	<ul style="list-style-type: none"> • 10 points for Rookie Teams • 5 points for second-year Teams

Points earned at District Championships are multiplied by three (3) and then added to points earned at District events, to determine the final season point total for the Team





Teams are ranked in decreasing order, using the following sorting criteria:

Table 10-8: District Team sort criteria

Order Sort	Criteria
1 st	Total Playoff Round Performance Points
2 nd	Best Playoff Round Finish at a single event
3 rd	Total ALLIANCE Selection Results Points
4 th	Highest Qualification Round Seed or Draft Order Acceptance (i.e. Highest ALLIANCE Selection points at a single event)
5 th	Total Qualification Round Performance Points
6 th	Highest Individual MATCH Score, regardless of whether that score occurred in a Qualification or Playoff MATCH
7 th	Second Highest Individual MATCH Score, regardless of whether that score occurred in a Qualification or Playoff MATCH
8 th	Third Highest Individual MATCH Score, regardless of whether that score occurred in a Qualification or Playoff MATCH
9 th	Random Selection

10.12.3.1 Qualification Round Performance

The calculation of Qualification performance points is done using the equation (an inverse error function) in the table above. The equation utilizes the following variables:

- R – the qualification rank of the team at the event at the conclusion of Qualification MATCHES (as reported by FMS)
- N – the number of *FIRST* Robotics Competition teams participating in the Qualification rounds at the event
- Alpha (α) – a static value (1.07) used to standardize the distribution of points at events

This formula generates an approximately normal distribution of Qualification Round Performance points at an event, based on rank, with most teams getting a moderate number of points, and fewer teams getting the highest or lowest numbers of points available.

Table 10-9 displays sample Qualification Round Performance points for variously ranked teams at a forty (40) team event. The system will automatically generate the appropriate points for each team based on their rank and the number of teams at the event.

Table 10-9 Sample Qualification Round Point assignments

Rank	1	2	3	4	...	19	20	21	...	37	38	39	40
Points	22	21	20	19	...	13	13	12	...	6	6	5	4

10.12.3.2 ALLIANCE Selection Results

This attribute measures both individual Team qualification round seeding performance and recognition by peers.

ALLIANCE CAPTAINS are recognized based on their qualification round seeding rank. This rank is a result of the rules of the game, which typically incorporate several team performance attributes, and are designed to eliminate ties in rank. Non-ALLIANCE CAPTAINS are rewarded based on peer recognition. To be invited to join an ALLIANCE, a Team's peers have decided that the Team has attributes that are desirable. Giving points for ALLIANCE selection also supports come-from-behind Teams. A Team taking several MATCHES to optimize their performance may be recognized as a late bloomer by a top seeded Team, even if that performance isn't reflected in the rankings because of poor performance in early





MATCHES. These points also have the potential to recognize Teams employing a minority strategy with their ROBOT. Teams with unique or divergent ROBOT capabilities that complement the strengths of other ALLIANCE members may be selected to fill a strategic niche.

Note also that ALLIANCE CAPTAINS are given the same number of points as the Team drafted in the same sequence. For example, the third ALLIANCE CAPTAIN gets the same number of points as the third draft. Numerical analysis supports the idea that ALLIANCE CAPTAINS are about as strong in ROBOT performance as equivalently drafted Teams. As an additional minor benefit, awarding the same points for ALLIANCE CAPTAINS and equivalent drafts lubricates the acceptance of draft offers between ALLIANCE CAPTAINS, which gives Teams out of the top eight the chance to experience being ALLIANCE CAPTAINS themselves.

10.12.3.3 Playoff Round Performance

This attribute measures Team performance as part of an ALLIANCE.

All Teams on the ALLIANCE winning a particular playoff series, who participate in MATCHES with their ROBOTS, receive five (5) points per MATCH won. In most cases, Teams receive ten (10) points at each of the Quarterfinal, Semifinal, and Final levels, unless a BACKUP ROBOT is called in to play.

10.12.3.4 Awards

This attribute measures Team performance with respect to judged Team awards.

The points earned for Team awards in this system are not intended to capture the full value of the award to the Team winning the award, or to represent the full value of the award to *FIRST*. In many ways, the Team's experience in being selected for awards, especially the Chairman's Award, the Engineering Inspiration Award, and the Rookie All Star Award, is beyond measure, and could not be fully captured in its entirety by any points-based system. Points are being assigned to awards in this system only to help Teams recognize that *FIRST*[®] continues to be "*More than Robots*[®]," with the emphasis on our cultural awards, and to assist in elevating award-winning Teams above non-award winning Teams in the ranking system.

Teams only get points for judged Team awards. If an award is not judged, e.g. Rookie Highest Seed, or is not for a Team, e.g. the Dean's List Award, no points are earned.

10.12.3.5 Team Age

This attribute recognizes the difficulty in being a Rookie or second-year Team.

Points are awarded to Rookie and second year Teams in recognition of the unique challenges Teams face in those early years, and to increase the chance that they will make it to the District Championship to compete with their ROBOTS. Like our dedicated Rookie awards, these additional points are intended to recognize and motivate newer participants in *FIRST*[®] Robotics Competition. These points are awarded once at the beginning of the season. Rookie year is calculated based on the year in which *FIRST* recognizes the Team as a Rookie.

10.12.3.6 Regional Participation

District Teams do not earn points for their actions at any Regionals they may attend, nor are eligible for *FIRST* Championship qualifying judged awards at those events. However, if a District Team does earn a slot at the *FIRST* Championship while attending a Regional event, that slot does count as part of the total Championship allocation the District is receiving for the season.

10.12.3.7 District Championship Eligibility

T24. A Team competing in a District qualifies for their District Championship by meeting one of the following criteria:





- A. District Chairman’s Award winner
- B. District Ranking; based on total points earned at their first two home District events as detailed in [Section 10.12.3 District Events](#).

Teams do not earn points at third or subsequent District events, nor at any inter-district or Regional events at which they compete during the 2017 season.

If a team declines an invitation to the District Championship, the next highest uninvited team on the list is invited, and so on, until the event capacity is filled.

- C. District Engineering Inspiration winner (qualifies to compete for the award only)
- D. District Rookie All Star winner (qualifies to compete for the award only)

The capacity of each District Championship is shown in Table 10-10. Each District determines the number of teams which qualify for their District Championship. These limits are based on factors including but not limited to the total number of teams in the District, available venue capacity, etc.

Table 10-10: 2017 District Championship Capacities

District Championship	2017 Team Capacity
Chesapeake District Championship	58
Indiana State Championship	32
Israel	45
Michigan State Championship	TBD
Mid-Atlantic Robotics District Championship	60
New England District Championship	64
FIRST North Carolina State Championship	32
FIRST Ontario Provincial Championship	60
Pacific Northwest District Championship	64
Peachtree District State Championship	45

10.12.3.8 *FIRST*® Championship Eligibility for District Teams

Districts receive the percentage of 'available slots' at their assigned *FIRST* Championship location, rounded up to the nearest whole slot, equal to the percentage of teams they have in their District compared to the total of all *FIRST* Robotics Competition teams in the current season who would normally be assigned to their *FIRST* Championship location. 'Available slots' are calculated by taking the total number of slots at each *FIRST* Championship location, subtracting the number of pre-qualified teams assigned to that location, and also subtracting a 10% allowance for waitlisted teams, as Districts are still allowed to send waitlisted teams to the *FIRST* Championship. Further, this overall calculation uses a 'snapshot' of teams that have registered and paid as of a specific day a week or so after season payment due.

These slots are guaranteed to the Districts and populated with the following teams:

- qualifying award winners from the District Championship (Chairman’s Award, Engineering Award, and Rookie All Star winners),
- teams on the Winning Alliance from the District Championship (including any Back-Up teams participating),
- qualifying award winners among district teams who traveled to Regionals,





- teams on the final District ranking list, as deep in the ranking list as the District needs to go to fill their allocation.

If a District team earns a slot to the *FIRST* Championship within the season, but is not able to attend, the top ranked team who has not yet been offered a slot is given the opportunity, and so on, until all slots are filled. Slots for pre-qualified teams will not be backfilled.

Districts determine the number of Dean's List, Chairman's, Rookie All Star, and Engineering Inspiration Awards to present at their Championship, within a range established by *FIRST* and shown in Table 10-11.

Table 10-11: District slot allocations for *FIRST* Championship

District	<i>FIRST</i> Championship St. Louis Slots		Dean's List Award			Chairman's Award			Rookie All Star Award		Engineering Inspiration Award			
	<i>FIRST</i> Championship Houston Slots		Max Ratio	Min Ratio	District Selection	Max Ratio	Min Ratio	District Selection	Max Ratio	Min Ratio	District Selection	Max Ratio	Min Ratio	District Selection
Chesapeake	-	23							1	2		1	2	
Indiana	-	10							1	2		1	2	
Israel	16	-							1	2		1	2	
Michigan	-	82							1	2		1	2	
Mid-Atlantic Robotics	-	22	TBD	TBD	TBD	TBD	TBD	TBD	1	2	TBD	1	2	TBD
New England	-	37	TBD	TBD	TBD	TBD	TBD	TBD	1	2	TBD	1	2	TBD
North Carolina	15	-							1	2		1	2	
Ontario	-	29							1	2		1	2	
Pacific Northwest	39	-							1	2		1	2	
Peachtree	18	-							1	2		1	2	





II Glossary

Term	Definition
AIRSHIP	a structure that features an elevated hexagonal deck, slanted walls, rails with AXLES to mount GEARS, four (4) ROTORS, three (3) LIFTS, a STEAM TANK, and three (3) ROPES attached to DAVITS
ALLIANCE	a cooperative of up to four (4) FIRST® Robotics Competition Teams
ALLIANCE CAPTAIN	The designated student representative from each ALLIANCE in a Playoff MATCH
ALLIANCE STATION	an 8 ft. 9¼ in. (~269 cm) by 23 ft. 1½ in. (~705 cm) infinitely tall volume bounded by the ALLIANCE WALL and ALLIANCE colored tape
ALLIANCE WALL	the physical structure that separates ROBOTS from DRIVE TEAMS (except the PILOT) and consists of a BOILER, three (3) PLAYER STATIONS, an Overflow LOADING STATION and a Return LOADING STATION.
ARENA	all elements and areas of the game infrastructure that are required to play FIRST STEAMWORKSSM: the FIELD, AIRSHIPS, carpet, scoring elements, and all equipment and areas needed for FIELD control, ROBOT control, and scorekeeping
ARENA FAULT	an error in ARENA operation that includes, but aren't limited to those listed in Section 10.8 MATCH Replays .
AUTO	the first fifteen (15) seconds of a MATCH in which ROBOTS operate without any DRIVE TEAM control or input
AXLE	a 7⁄8-in. diameter (~2 cm), 2-in. (~5 cm) long shaft which fits the central hub of a GEAR. AXLES are installed on the RAIL of the AIRSHIP.
BACKUP TEAM	The Team whose ROBOT and DRIVE TEAM replaces another ROBOT and DRIVE TEAM on an ALLIANCE during the Playoff MATCHES
BANNER	a Team's flag to be displayed on their PLAYER STATION during MATCHES (see specifications here)
BASE LINE	a green line that spans the width of the FIELD and is 7 ft. 9¼ in. (~237 cm) from the ALLIANCE WALL diamond plate
BOILER	a FIELD element which converts FUEL to steam. There is a BOILER on each corner of the FIELD opposite the scoring table. The base of each BOILER is 3 ft. 6 in. wide (~107 cm) by 3 ft. 6 in. (~107 cm) deep by 8 ft. 1 in. (~246 cm) tall. There are two (2) openings, or GOALS, for loading FUEL into the BOILER: the High Efficiency GOAL and the Low Efficiency
BUMPER	a required assembly which attaches to the ROBOT frame. BUMPERS are important because they protect ROBOTS from damaging/being damaged by other ROBOTS and FIELD elements
BUMPER ZONE	the volume contained between the floor and a virtual horizontal plane 7 in. (~17 cm) above the floor in reference to the ROBOT standing normally on a flat floor
BYPASSED	any ROBOT which is unable or ineligible to participate in that MATCH as determined by the FTA, LRI, or Head REFEREE resulting in a ROBOT which is disabled)
COACH	a precollege student or adult mentor member of the DRIVE TEAM responsible for acting as a guide or advisor
COMPONENT	any part in its most basic configuration, which cannot be disassembled without damaging or destroying the part or altering its fundamental function
COTS	a standard (i.e. not custom order) part commonly available from a VENDOR for all Teams for purchase. To be a COTS item, the COMPONENT or MECHANISM must be in an unaltered, unmodified state.





Term	Definition
CRANK	a handle located with the first GEAR in the set
CUSTOM CIRCUIT	any electrical component of the robot other than motors, pneumatic solenoids, roboRIO, PDP, PCM, VRM, RSL, 120A breaker, motor controllers, relay modules, wireless bridge, or batteries.
DAVIT	one of three steel frames that attaches a ROPE to the AIRSHIP
DISABLED	a state in which a ROBOT is commanded to deactivate all outputs, rendering the ROBOT inoperable for the remainder of the MATCH
DISQUALIFIED	the status of a Team, as determined by the Head REFEREE, in which their Team receives zero (0) Match points in a qualification MATCH or causes their ALLIANCE to receive zero (0) Match points in a Playoff MATCH
DRIVER	a precollege student member of the DRIVE TEAM responsible for operating and controlling the ROBOT
DRIVE TEAM	a set of up to five (5) people from the same FIRST Robotics Competition Team responsible for Team performance during a MATCH
FABRICATED ITEM	any COMPONENT or MECHANISM that has been altered, built, cast, constructed, concocted, created, cut, heat treated, machined, manufactured, modified, painted, produced, surface coated, or conjured partially or completely into the final form in which it will be used on the ROBOT
FIELD	a 27 ft. by 54 ft. 4 in. (~823 cm by ~1656 cm) area, bounded by and including the upward- and inward-facing surfaces of the GUARDRAILS and ALLIANCE WALLS
FIELD STAFF	REFEREES, FTAs, or other staff working around the FIELD
FMS	the Field Management System (FMS)
FOUL	a penalty assessed by a REFEREE upon a rule violation resulting in 5 points credited towards the opponent's total score
FRAME PERIMETER	the polygon contained within the BUMPER ZONE, that is comprised of fixed, non-articulated structural elements of the ROBOT
FTA	a FIRST Technical Advisor
FUEL	a GAME PIECE used to generate steam for the AIRSHIP and is represented by "Screamin' Yellow," 5 in. (nominal) diameter Gopher ResisDent™ polyethylene balls
GAME PIECE	GEAR or FUEL
GEAR	a GAME PIECE that is a toothed wheel used to start ROTORS on the AIRSHIP. Each GEAR is made from gold (Pantone PMC 124C) polypropylene, has 10 teeth, an 11 in. (~28 cm) diameter, 10 in. (~25 cm) pitch diameter, and is 2 in. (~5 cm) thick
GOAL	an opening for loading FUEL into the BOILER
GUARDRAIL	a system that consists of transparent polycarbonate supported on the top and bottom by aluminum extrusion. The GUARDRAIL prevents ROBOTS from inadvertently exiting the FIELD during a MATCH.
HOPPER	a pair of containers located just outside the FIELD and used to store FUEL at the start of the MATCH
HUMAN PLAYER	a pre-college student DRIVE TEAM member responsible for managing GAME PIECES
KEY	an infinitely tall volume in the ALLIANCE'S LAUNCHPAD bounded by the ALLIANCE WALL, GUARDRAIL, and ALLIANCE colored tape
KOP	Kit of Parts, the collection of items listed on any Kickoff Kit Checklists, distributed via FIRST® Choice, or obtained via a Product Donation Voucher (PDV).
LAUNCHING	shooting in the air, kicking or rolling across the floor with an active mechanism, or throwing in a forceful way





Term	Definition
LAUNCHPAD	an infinitely tall volume in the FIELD bounded by the GUARDRAILS, the ALLIANCE WALL, and the LAUNCHPAD LINE. The volume above the LAUNCHPAD LINE is part of the LAUNCHPAD.
LAUNCHPAD LINE	a tape line that is the width of the FIELD and collinear with the edge of the AIRSHIP deck that is closest to the center of the FIELD
LIFT	an assembly used to transfer GEARS from the ROBOTS to the PILOTS
LINEUP	The list of three (3) Teams participating in the MATCH and their selected PLAYER STATIONS
LOADING LANE	an area bounded by and including ALLIANCE colored tape, edge of the carpet, the RETURN BIN Table, and the opponent's ALLIANCE WALL
LOADING STATION	an assembly used to feed FUEL and GEARS on to the FIELD. Each Return LOADING STATION includes a 6 ft. 6 in. (~198 cm) in. tall and 6 ft. 3½ in. (~192 cm) wide polycarbonate panel with two (2) openings, aluminum frame.
RETRIEVAL ZONE	an infinitely tall volume inside the FIELD bounded by the ALLIANCE WALL, GUARDRAIL and ALLIANCE colored tape. The RETRIEVAL ZONE includes the volume above the tape.
MATCH	a two (2) minute and thirty (30) second period of time in which ALLIANCES play <i>FIRST STEAMWORKS</i>
MECHANISM	a COTS or custom assembly of COMPONENTS that provide specific functionality on the ROBOT. A MECHANISM can be disassembled (and then reassembled) into individual COMPONENTS without damage to the parts
MXP	MyRIO eXpansion Port, the expansion port on the roboRIO
NEUTRAL ZONE	an infinitely tall volume on the FIELD bounded by the GUARDRAILS and the LAUNCHPAD LINES. The volume above the LAUNCHPAD LINES is not part of the NEUTRAL ZONE
OPERATOR CONSOLE	the set of COMPONENTS and MECHANISMS used by the DRIVERS and/or HUMAN PLAYER to relay commands to the ROBOT
OVERFLOW BIN	one of the plastic open-topped containers, 2 ft. 9½ in. (~85 cm) wide by 1 ft. 6 in. (~46 cm) deep by 1 ft. 1 in. (~33 cm) tall, and each has a capacity of approximately fifty to sixty (50-60) FUEL
PASSIVE CONDUCTORS	any device or circuit whose capability is limited to the conduction and/or static regulation of the electrical energy applied to it (e.g. wire, splices, connectors, printed wiring board, etc.)
PCM	Pneumatic Control Module
PDP	Power Distribution Panel
PILOT	a pre-college student DRIVE TEAM member responsible for installing GEARS, starting ROTORS, and deploying ROPES
PLAYER STATION	one (1) of three (3) assigned positions in an ALLIANCE WALL from where a DRIVE TEAM operates their ROBOT
RED CARD	a penalty assessed for egregious ROBOT or Team member behavior, or rule violations, which results in a Team being DISQUALIFIED for the MATCH
REFEREE	an official who is certified by <i>FIRST</i> to enforce the rules of <i>FIRST STEAMWORKS</i>
RETURN BIN	one of the plastic open-topped containers, 2 ft. 9½ in. (~85 cm) wide by 1 ft. 6 in. (~46 cm) deep by 1 ft. 1 in. (~33 cm) tall, and each has a capacity of approximately fifty to sixty (50-60) FUEL
ROBOT	an electromechanical assembly built by the FIRST® Robotics Competition Team to perform specific tasks when competing in FIRST® STEAMWORKSSM. The ROBOT must include all of the basic systems required to be an active participant in the game – power, communications, control, BUMPERS, and movement. The ROBOT implementation must obviously follow a design approach intended to play FIRST STEAMWORKS





Term	Definition
ROPE	a strong, thick string composed of twisted or braided strands of manila, hemp, flax, or the like, secured to the airship, and used to secure robots for flight at the end of the match
ROTOR	one of four (4) rotating airfoils
RP	Ranking Point, a unit credited to a Team based on their ALLIANCE'S performance in Qualification MATCHES
RS	Ranking Score, the total number of Ranking Points earned by a Team throughout their Qualification MATCHES
STARTING CONFIGURATION	the physical configuration and orientation of the ROBOT at the beginning of the MATCH where no part of the ROBOT shall extend outside the vertical projection of the FRAME PERIMETER, with the exception of its BUMPERS and minor protrusions such as bolt heads, fastener ends, rivets, etc.
STARTING LINE	a white tape line that runs the width of the carpet and is 2 ft. 6 in. (~76 cm) behind the ALLIANCE WALL diamond plate
STEAMACRIT	one who complains about non-working gears being used while coating a Nerf gun with paint and calling it a raygun. (courtesy " TimeTinker " on The Steampunk Forum at Brass Goggles)
STEAM PIPE	a clear PVC pipe that transfers steam from the BOILER to the STEAM TANK on the AIRSHIP
STEAM TANK	a 6-ft. (~183 cm) tall hexagonal container with a diagonal dimension of 2 ft. (~61 cm) centrally mounted on the deck. It is "filled" via a STEAM PIPE that originates at the BOILERS.
SURROGATE	a Team randomly assigned by the FIELD Management System to play an extra Qualification MATCH
TECH FOUL	25 points credited towards the opponent's total score
TELEOP	the second period in a MATCH and is two minutes and fifteen seconds (2:15) long
TIMEOUT	a period of up to six (6) minutes between MATCHES which is used to pause Playoff MATCH progression
TOUCHPAD	a 10 in. (~25 cm) polycarbonate plate mounted 4 ft. 10 in. (~147 cm) above the carpet and used to determine if a ROBOT has successfully latched on to the AIRSHIP
VRM	Voltage Regulator Module
WITHHOLDING ALLOWANCE	a static set of FABRICATED ITEMS that shall not exceed 30 lbs. (~13 kg.), brought to an event (or Robot Access Period) in addition to the bagged items, to be used to repair and/or upgrade their ROBOT
YELLOW CARD	a warning issued by the Head REFEREE for egregious ROBOT or Team member behavior or rule violations. A subsequent YELLOW CARD within the same tournament phase will lead to a RED CARD.

